

PROJECTS IN HOLOGRAPHY



The field at a glance

Holography is both an artistic medium and a technical tool. This manual will teach you the basic skills in both fields.

Many spectacular artistic holograms may be seen in exhibitions. The most complete collection is continuously on view at the New York Museum of Holography, which also publishes a monthly journal, the HOLOSPHERE.

Technical applications of holography are taught in most colleges and universities, and are described in scientific journals, magazines, and textbooks. There is a large, rapidly growing number of industrial uses of holography.

What makes holography exciting is the ability of a hologram to record a three dimensional image and to recreate the original scene faithfully at a later time. In effect a hologram freezes an instant of time.

Practical Applications

The exactness of the holographic image makes it invaluable for detecting faults – in aircraft tires, automobile clutch plates, brake drums, gas pipelines, and high pressure tanks. It is also an important diagnostic tool which makes dramatically visible the flow of air through wind tunnels, displays the micro-inch growth of plants, and depicts the vibration patterns of mechanical components and structures. The latter can assist in detecting cracks or imbalances in turbine blades, and can help in the design of quieter automobiles.

The ability to freeze an instant in time makes holography useful in studying dynamic objects, such as biomedical specimens in laboratories or crystal growing on the skylab; and the precision and three-dimensionality of its image make it useful in recording precious gems for purposes of absolute identification.

In many ways, holography has grown in parallel with electronic information processing. In addition to its use for optical data storage in certain computers, it has various more specialized uses: credit card verification systems; universal product code scanning; aviation displays on pilots' helmets; viewing distant enemy territory via side-looking radar; automatically recognizing objects in photos; detecting bacteria; spotting enemy troop activity; and even resharpening blurred photographs.

What would you like to do with holography?

As you can see, there are many varied applications of holography. If you know which direction you want to go with this technology, you may wish to select the experiments in this manual that relate to the goals you have chosen. It's more likely, however, that you will wish to go through most of the experiments described here, in order to get an overall picture of the techniques and applications of this fascinating concept.

This manual, together with the HL-1 or HL-1a system, a laser, and film supplies, are all you need to perform a wide variety of coherent optical experiments. It doesn't even take a lot of time to get nice results. Most of the holograms described in this manual can be made in less than an hour, even if you are new to holography.

Custom-designed setups

No doubt you will soon find yourself becoming increasingly fascinated with holography and spending more and more time with it. As you do, you'll begin to discover that there are certain things that only you know how to do. You'll find yourself freely revising the setups to suit your particular needs and then adding little complexities to your setups, and even expanding the system's capabilities with additional components. This seems to be the nature of holography. And to satisfy these requirements, the HL-1 system has been designed to a professional level, as a fully versatile system.

TO SUMMARIZE, you'll start right off making basic holograms – optically suspending objects in space and time. And you'll explore at least some of the more complex phenomena covered later in the booklet. But at some point, according to your inclination, you'll start adapting the technology to your own purposes.

Find a good spot for your lab

A modest degree of **DARKNESS** will be required during holographic experiments, so pick a room that can be darkened. And keep in mind that **AIR MOTION** is undesirable when making hologram exposures.

Your isolation platform, when it **FLOATS FREE** on air-cushion balloons, will be well isolated from the disturbing effects of ground vibrations. Inflate the four balloons and place them in the recesses under the platform. Place the platform on a sturdy table or on the floor. You can demonstrate for yourself how free from vibration the damped isolation platform is on its air cushions, and also how air motion can degenerate holograms, by performing the Michelson interferometer experiment described on page 24.

CONTENTS

Learning the basics (Making a simple hologram)	2
Two-beam transmission holograms	4
Focused-image hologram (Viewable in white light)	6
Reflection hologram (Viewable in white light)	8
Rainbow hologram (Viewable in white light)	10
Holographic stereogram portraits (Viewable in white light)	12
Optical image processing	14
Optical data storage	16
Holographic interferometry (Double exposure)	18
Real-time holographic interferometry	20
Vibration analysis (Time-average interferometry)	22
Michelson interferometer	24
Test exposures	26
How to copy a hologram	26
Reference material	26
Components list	30

LEARNING THE BASICS BY MAKING A SIMPLE HOLOGRAM

This first hologram you'll make is of the **TRANSMISSION TYPE**. That is, when you're ready to view it you'll hold it up between you and the light source, and thus the light that propagates to your eyes as an image is being transmitted through the hologram plate. (This is in contrast to the case of reflection-type holograms.)

The hologram will display both the **VIRTUAL IMAGE** and the **REAL IMAGE**. The virtual 3-D image is the one that appears to lie beyond the hologram plate and is seen by looking through the hologram (as if looking through a window pane). The "real" 3-D image is the one that extends out in front of the hologram plate (toward your face), requiring you to step back in order to see it.

Placement of Components

Mount everything at the locations shown. Screw down the thumb screws of the base clamps (but not overtight). Wipe off any debris that's under the mounts, so they'll rest down solidly.

Film Plate Holder

Put a 4" x 5" paper into the plateholder to help you see the light pattern that would expose the film plate.

The Laser

Adjust the mounts so the laser light travels 3" above the table top. (If you're using a polarized laser, it's preferable to mount it in its standard upright orientation, then its polarization will be vertical.)

Lenses and Mirrors

Don't overtighten the glass items in their mounts. Just make them snug enough not to wobble. (Overstressing can cause elastomeric creep.) Don't touch the optical surfaces. For cleaning off dust, use a hand blower.

Alignment Procedure

1. Align mirror M_1 so that the reflected beam strikes near the center of the plateholder PH.
2. Use lens L_1 to spread out the laser beam that's reflected from M_1 , and then readjust M_1 until the plateholder is broadly illuminated.
3. Place the swan or any groundglass-like object in the laser beam so it casts a shadow that touches partway onto the film plate.

Reference Beam – the light that travels directly to the film without striking the object.

Object Beam – the light that strikes the object and is therefore diffused before it travels on toward the film.

Shuttering. To control the exposure interval, keep a piece of cardboard leaning against the output end of the laser, then momentarily lift the cardboard out of the way of the laser beam, and count the seconds (approximate is OK) for the desired length of exposure. Don't bump the apparatus and cause vibrations.

Hologram Exposure (room darkened)

Put a filmplate into the plateholder, seating the plate carefully so that it can't move during exposure. Face the light-sensitive emulsion side (the side that's sticky when touched by a damp object such as your lip) toward the laser beam.

For this experiment, the exposure time will be about 2-3 seconds with a 2-milliwatt laser and 8E75HD film; 5-10 seconds with 120-type film. (A method to figure out optimum exposure time is given on page 26.) After processing, the filmplate should be about as dark as medium sunglasses.

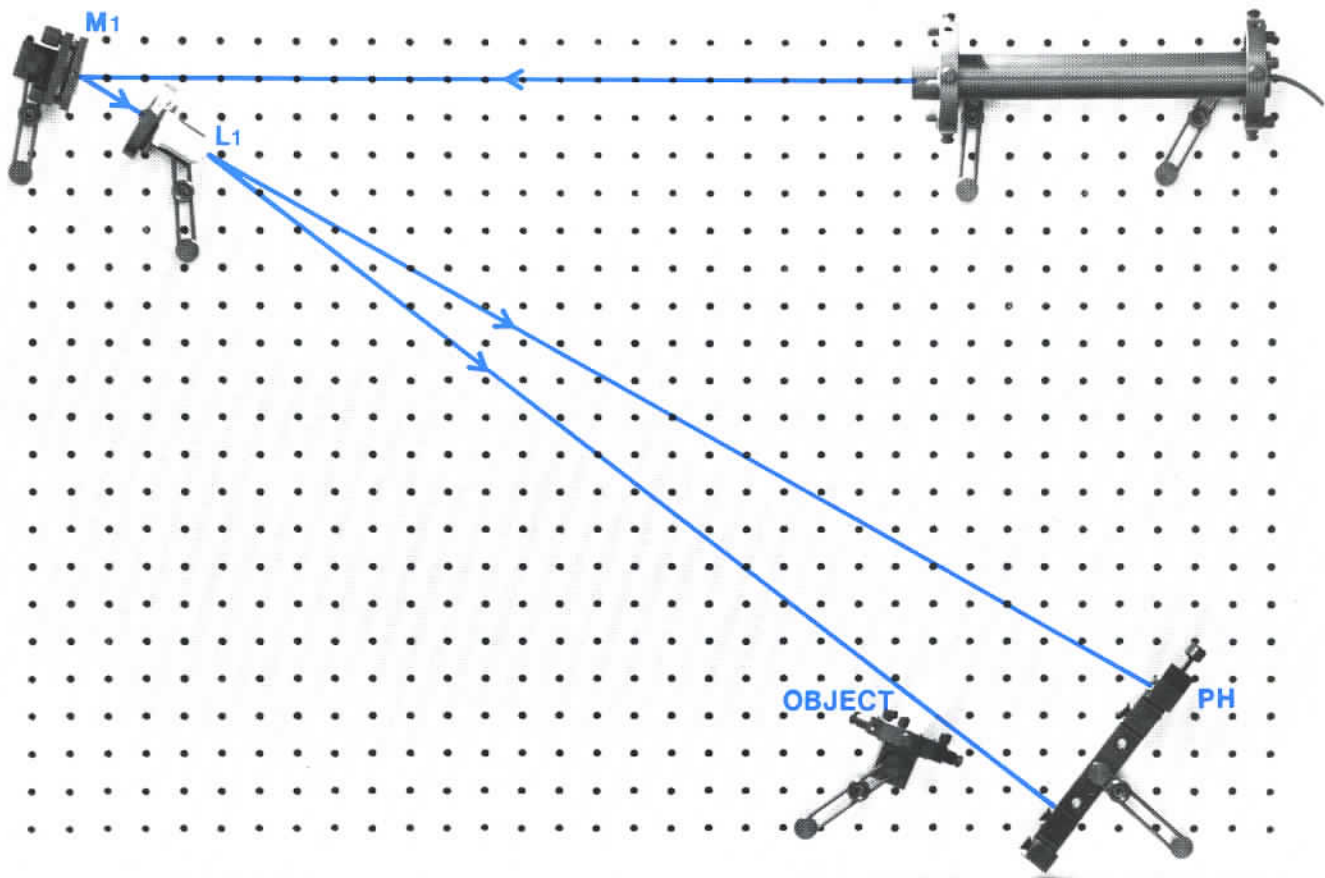

Processing the Film (room darkened)

- Standard darkroom trays can be used.
- D-19 developer, 4-7 minutes, constant agitation.
- Plain water, 30 seconds.
- Kodak Rapid Fixer (omit part B), 3-5 minutes.
- Running water (lights OK), 5 minutes.
- If you like, a brief rinse using photo-flo to prevent water marks.
- To dry the plate lean it against a wall, edge resting on a paper towel.

Quicker Processing. If pinched for time, reduce the develop, fix, and wash to 2 minutes each, then dry the plate by sloshing in alcohol for 30 seconds. Double the exposure time to compensate.

Bleach (optional, makes holograms clear). Simply dissolve iodine crystals in alcohol, one teaspoonful per quart. Dip hologram in for a few seconds, till clear, then rinse with cold or warm water for a few

minutes. Use rubber gloves. (Sometimes an overexposed hologram can be saved by bleaching.)

Displaying the Hologram (room lights dimmed)

Put the dried plate back in the plateholder exactly the way it was during exposure. Illuminate the hologram with the reference beam, but block the swan itself from view with a piece of cardboard, or remove the swan. Now looking through the hologram, you'll see a lifelike holographic image (the virtual image) being reconstructed.

Real Image (room lights dimmed)

There is also a "real" image, that is, an image that stands out in front of the hologram. You'll have to stand several feet back from the hologram and look in through it toward the reference beam. The real image will be somewhat magnified, with only portions of it visible at a time. If you have trouble seeing it, try moving your head back and forth.

TWO-BEAM TRANSMISSION HOLOGRAMS

Now you're ready to make holograms of opaque objects in addition to the translucent object of the previous experiment. With this setup you can get a more optimum ratio between reference beam and object beam, yielding a much brighter hologram.

Alignment Checklist

1. Mount everything at the exact locations shown.
2. The object is centered about 3" above the platform and positioned such that the VIEWABLE SIDE (the part facing the plateholder) sits over the X's in the photo. Large objects: Affix directly to isolation platform with touch of glue. Small objects: Improvise a pedestal, or use an adjustable-radius chuck.
3. The beamsplitter mount (BS) has 3 inserts: (1) 50%-reflecting, (2) 5%-reflecting, (3) 100%-reflecting. Using the 5% insert, split the laser beam into a reference beam and an object beam. The reflected beam (to use for reference beam) should strike near the center of M_2 .
4. The beam reflected from M_2 should strike near the center of the plateholder (PH).
5. Adjust M_1 so the laser beam strikes the object.
6. Position L_1 at the center of the laser beam, to spread the light. Position L_1 to suit your object (closer to small objects, farther from large objects). If you like, put a concave lens (L_3) prior to L_1 to spread the beam even wider.
7. Use white paper placed in the plateholder to see how much light reflected from the object will fall onto the filmplate.
8. Use L_2 to spread the REFERENCE BEAM. Move L_2 back and forth until the intensity on the white paper is about two to three times BRIGHTER than the light from the object.
9. Check that object beam is SAME LENGTH as reference beam: Reference path = beamsplitter $\rightarrow M_2 \rightarrow$ center of plateholder. Object path = beamsplitter $\rightarrow M_1 \rightarrow$ front of object \rightarrow plateholder.

Exposure Time (room darkened)

If you use the subject supplied and arrangement as shown, exposure is about 10-20 seconds with a 2-milliwatt laser, 8E75HD film; or 40 seconds with 120-type film. Emulsion side toward laser beam.

Film Processing (room darkened)

Same as page 3.

Displaying the Hologram (room lights dimmed)

Put the dried plate back in the plateholder exactly the way it was during exposure. Replace the 5% beamsplitter insert with the 100% insert, then fine-adjust it to direct all the energy into the reference beam. This will illuminate the hologram plate as brightly as possible.

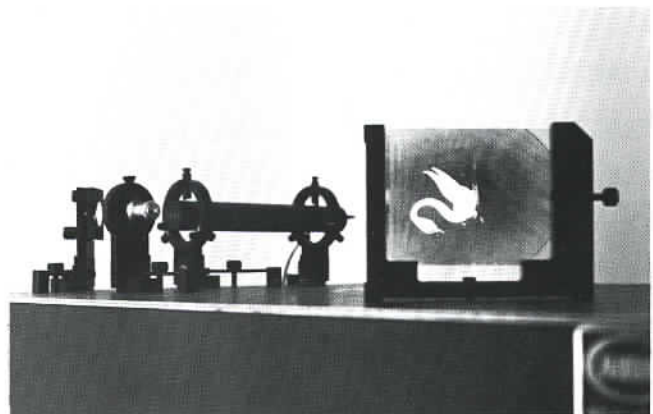

To display the finished hologram, a simpler layout can be used. In this case, only an illumination beam is used to reconstruct the image.

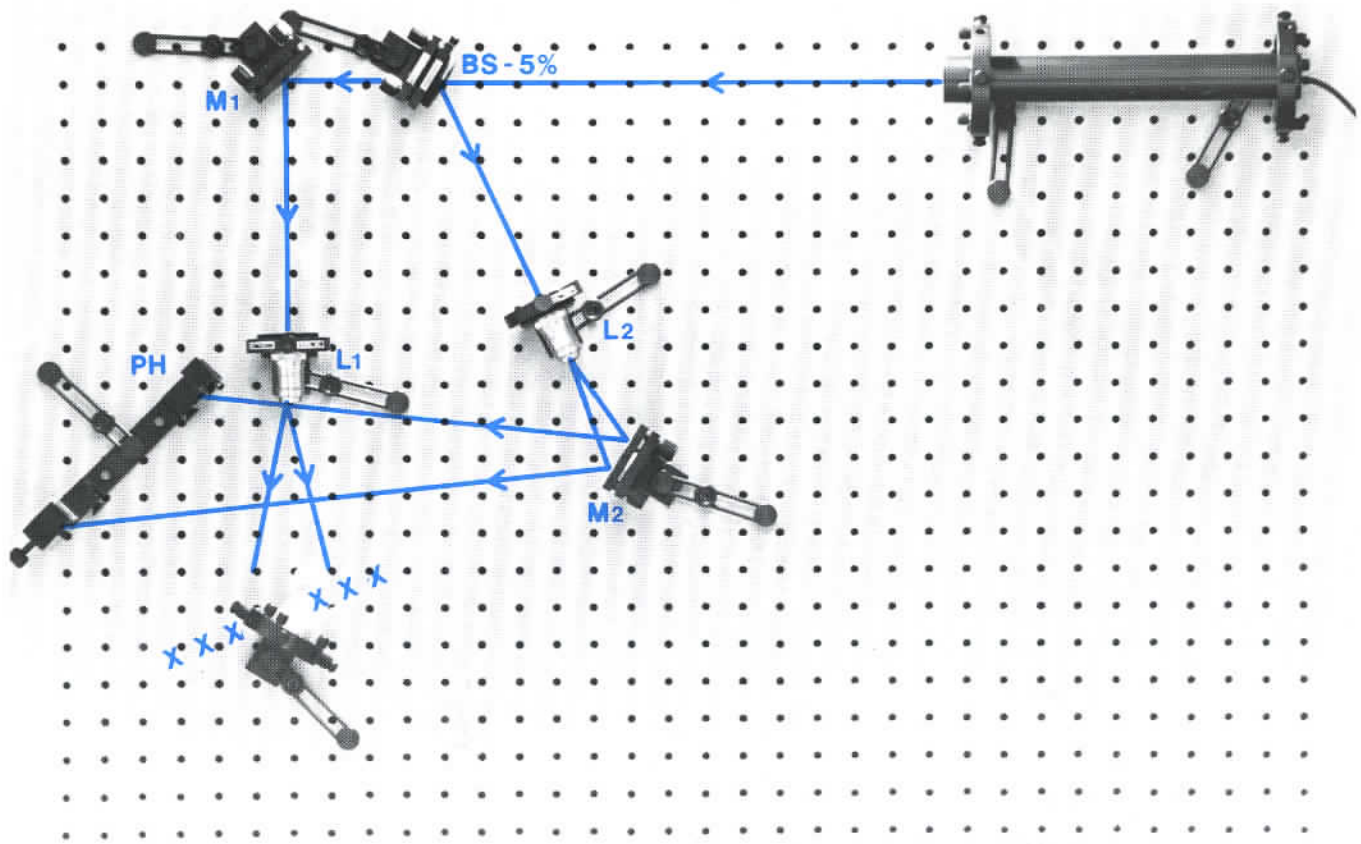

FOCUSED-IMAGE HOLOGRAM (viewable in white light)

If you have a favorite color slide, here's a way to make a hologram from it. (Or, if you want optimum panchromatic grey tones, make the hologram from a black-and-white slide.)

Alignment Checklist

1. Mount the plateholder PH with its longest dimension vertical; thus the filmplate will be held 5" vertical x 4" horizontal.
2. Use the 50%-reflecting insert for the beamsplitter, partially reflecting the laser beam toward mirror M₂.
3. Check that both beam paths (from the beamsplitter to the center of the plateholder) are the same length.
4. The groundglass GG, in vertical holder, intercepts the laser beam from mirror M₃ and spreads it over the area of the plateholder – a reference beam of sorts.
5. The microscope objective L₁ spreads out the beam to illuminate the groundglass more broadly.
6. Mount lens L₄ curved side toward the paper that's in the plateholder, spaced 6.25" from it. Place L₄ such that the beam hits the same spot (the center) of the paper after L₄ is in place as it did before.
7. Position lens L₅ such that the light passes through it as well as L₄, and hits the same spot (the center) of the paper after L₅ is in place as it did before.
8. Position the microscope objective L₂ such that the broad beam transmitted via M₂ will cover the central area of L₅.
9. The slide transparency is in a vertical holder, spaced 9.25" from the paper in the plateholder. The side the picture is viewed from faces toward lens L₅. The picture stands on its left edge (its top is to the side, toward L₁). The image is projected inverted onto the paper.
10. The tall mount near the plateholder serves to keep the direct light through the groundglass from striking the edge of the filmplate. Additionally, for best results you may wish to minimize stray light throughout the setup by blocking it with cardboard, etc.

Exposure Time (room darkened)

About 20 seconds with 2-milliwatt laser, 8E75HD film; 40-60 seconds with 120-type film. Emulsion side toward laser beam.

Film Processing (room darkened)

Same as page 3.

Viewing the Hologram

Face yourself toward an overhead light bulb or the sun (rather than a broad source). View the hologram with the emulsion side toward you, the light shining down on the hologram from above and behind it.

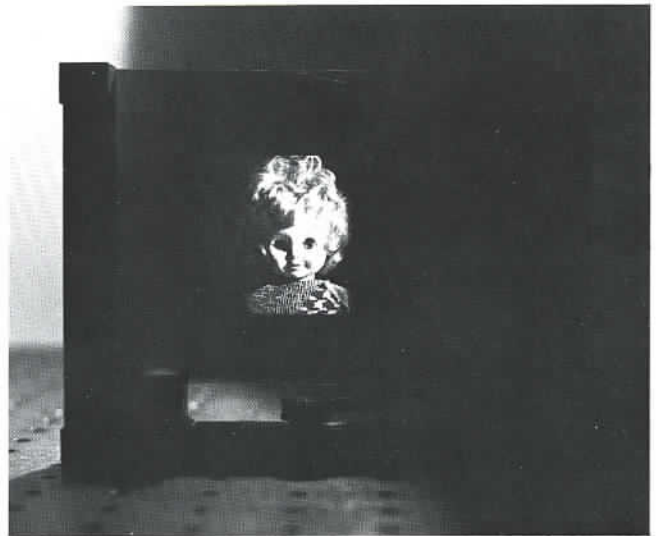

White light beaming down on the hologram from behind is used to view the image as shown.

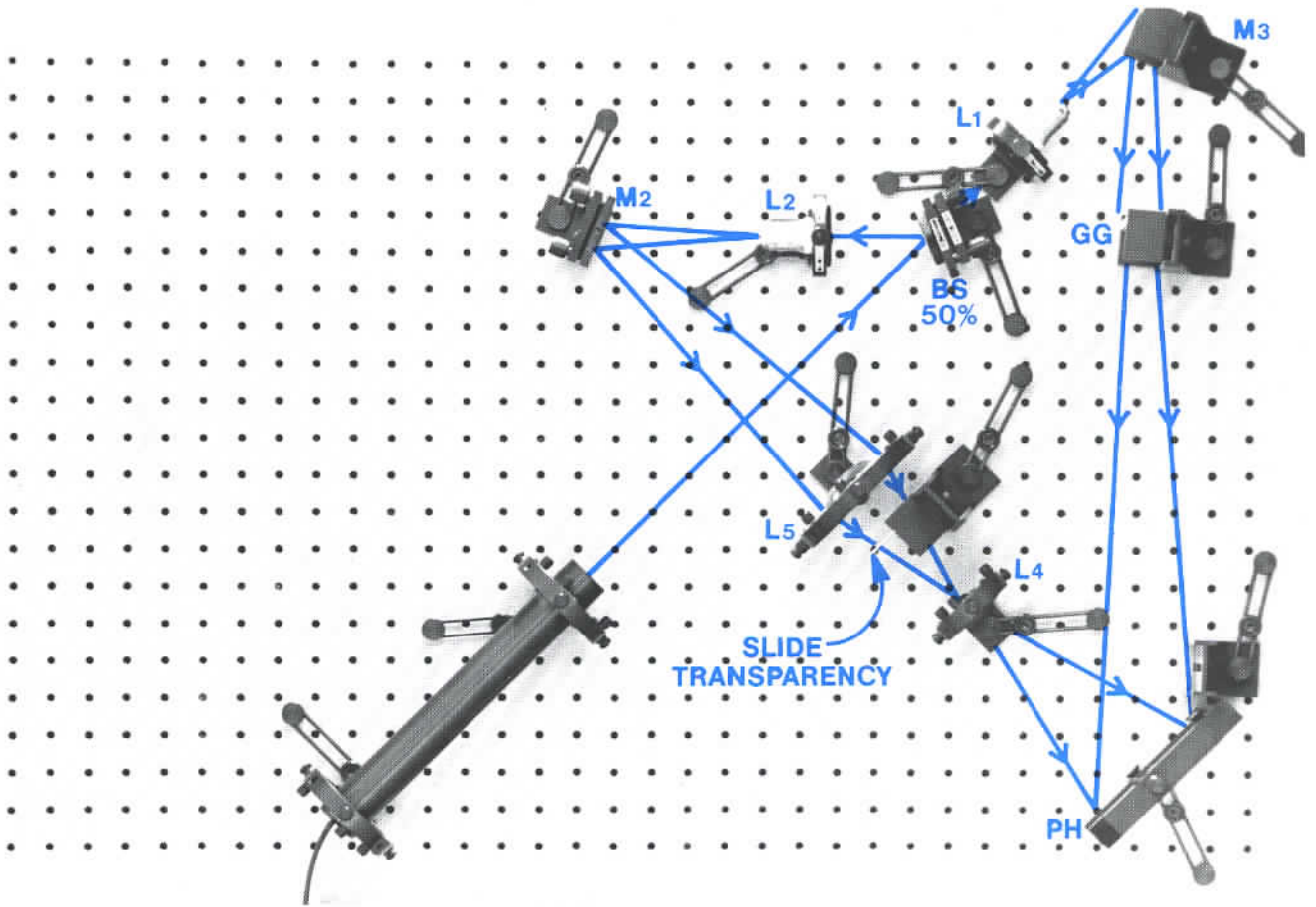

REFLECTION HOLOGRAM (viewable in white light)

This is a popular kind of hologram to make. It's viewable in white light, plus you don't have to be very careful how you hold it for viewing or exactly which way you illuminate it.

It's a reflection hologram, which means it's illuminated from the front for viewing. In other words, the rays from the light source don't come through from behind the hologram as they would for a transmission hologram.

Alignment Checklist

1. The plateholder will hold the filmplate 5" vertical x 4" horizontal.
2. The object is mounted sidewise rather than right-side-up.
3. Use the 50%-reflecting insert in the beamsplitter so that half the light goes to mirror M₁ and half to M₂.
4. The laser beam from M₁ should be fine-adjusted to go through microscope objective L₁ and illuminate the object.
5. The laser beam from M₂ goes through microscope objective L₂, spreading out a reference beam onto the opposite side of the filmplate from the object.
6. The tall mounts here serve merely to block off certain portions of the light. The mount T₁ keeps the beam through L₁ from striking the film directly – this light should strike only the object.
7. The mount T₂ prevents the reference beam through L₂ from striking onto the very edge of the filmplate. In other words the reference beam should strike the entire face of the filmplate except the edge that's toward T₁.
8. The mount T₃ prevents the stray light that might be scattered by M₁ from striking the filmplate.

Exposure Time (room darkened)

About 7-10 seconds with 2-milliwatt laser, 8E75HD film; 20-30 seconds with 120-type film. Emulsion side toward object.

Film Processing (room darkened)

Same as page 3.

Viewing

The hologram is best viewed in direct sunlight, preferably while being held in front of a dark background. If, after the filmplate is dry, you apply a light coat of flat-black spray paint to the emulsion side, this will serve quite well as a dark background.

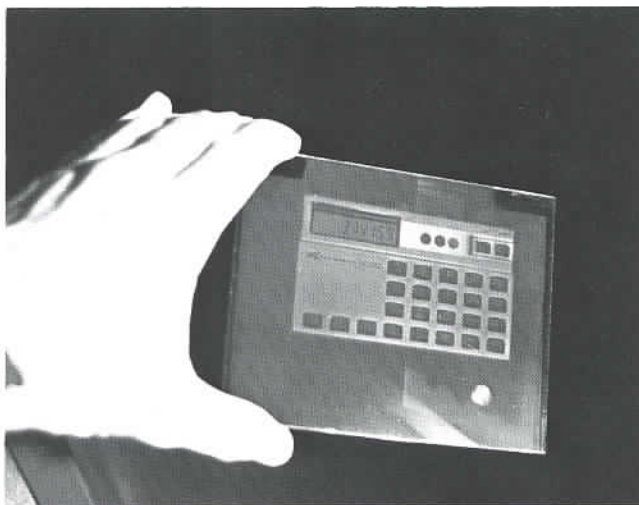

This reflection hologram is made in an even simpler way. The calculator is leaned against the film plate, keyboard contacting the film emulsion, and is exposed to a broad laser beam (for about a second) with everything sitting still. This technique is applicable to reflective objects that are relatively flat.

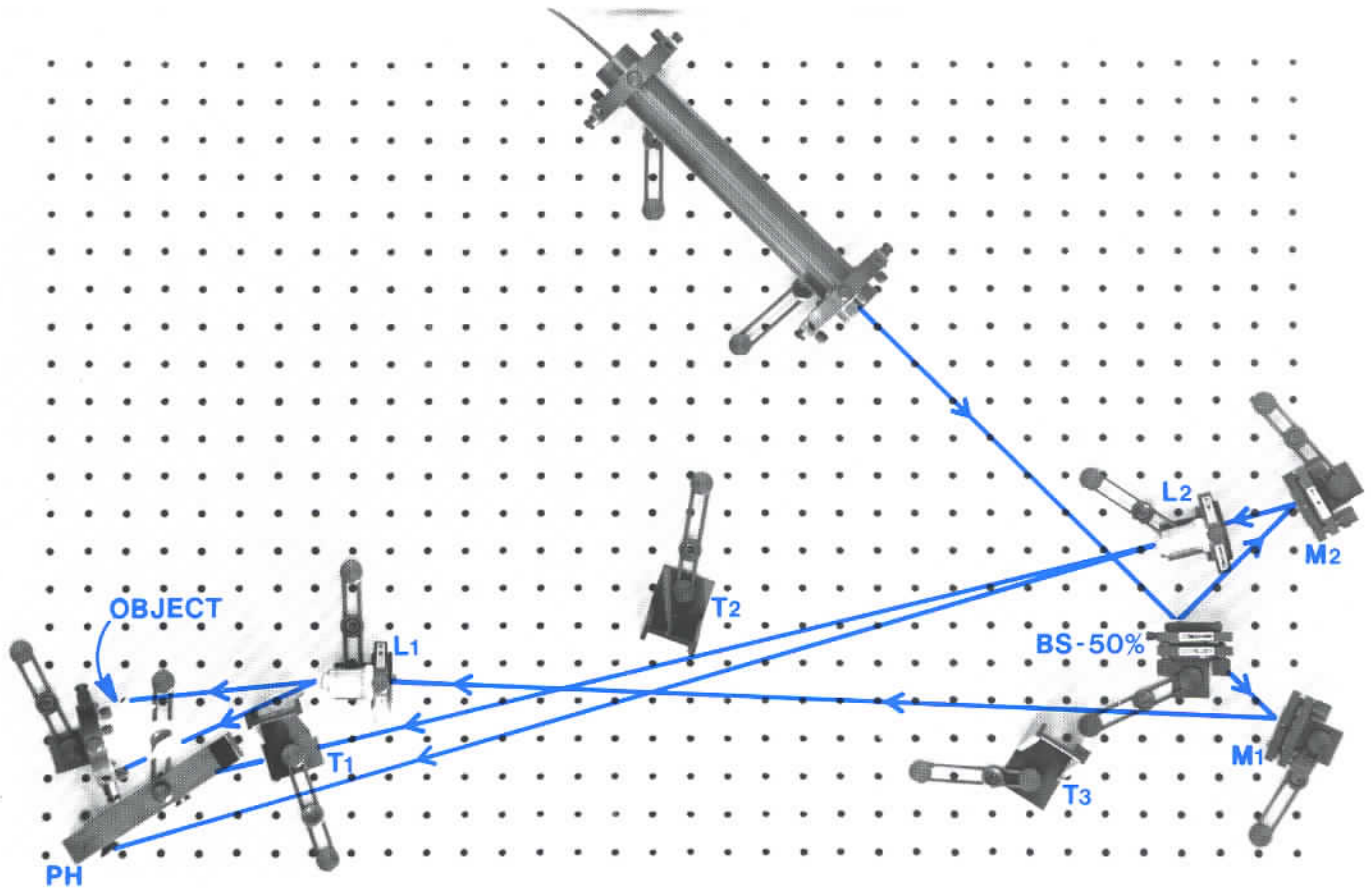

RAINBOW HOLOGRAM

(viewable in white light)

This rather artistic version of a rainbow hologram is made by a simple, single-step method. It displays a sharp 3-D real image of an object which appears in silhouette, standing out against a vivid, rainbow-colored background.

Alignment Checklist

1. Mount the plateholder with its longest dimension vertical; thus the filmplate will be held 5" vertical x 4" horizontal.
2. Use the 50%-reflecting insert for the beamsplitter, partially reflecting the laser beam toward the long tall mirror M₃.
3. Cylindrical lens L₆ (a 5mm-diam. glass rod mounted horizontally in a ring mount) spreads out the beam as a long vertical line on mirror M₃. Adjust the beamsplitter, and M₃, until the bright portion of the line strikes the central part of the plateholder.
4. Then insert the tall cylindrical lens L₇ such that it transmits the vertical line on toward the center of the plateholder.
5. Position the vertical groundglass GG about 2" from L₇, and L₇ will sharply focus the vertical line onto GG. The uniform, diffuse light transmitted by GG will provide the object beam for the hologram.
6. Microscope objective L₁ spreads light broadly over the plateholder while reflecting it off M₂. This (the reference beam) is brighter on the plateholder than the object beam from GG.
7. A piece of cardboard can be taped to a microscope-objective mount and used as a baffle. Position it to mask the reference beam from M₂ from striking the near edge of the filmplate.
8. Your object is placed in the area indicated. Orient it sidewise (the edge of the filmplate toward L₆ will be the bottom of the hologram). Try an improvised wire sculpture as object, formed by twisting some paper clips. Make it stick out sidewise from a chuck mount, and just far enough from the plateholder so the light from M₂ can't cast a shadow of the object onto the filmplate.

Exposure Time (room darkened)

About 2-3 seconds with 2-milliwatt laser, 8E75HD film; 5-10 seconds with 120-type film. Emulsion side toward laser beam.

Film Processing (room darkened)

Same as page 3.

To View the Rainbow Hologram

Face yourself toward an overhead light bulb or the sun (rather than a broad source). Hold the hologram horizontal, proper edge down (see 8), and the emulsion side toward you. The light should shine down on the hologram from above and behind it. The image will appear to protrude out from the hologram toward you. An image that stands out like this is called a real image.

Try also viewing the virtual image, by flipping the hologram upside-down, emulsion side away from you. If you have a Fresnel lens, try laying it over the hologram for viewing the virtual image.

Further Experiments with this setup

Try putting an object very close to the plateholder. During exposure, some of the reference-beam light will reflect from the filmplate and illuminate the front of the object.

Try making holograms of other things that might look interesting in silhouette but wouldn't be rigid enough for ordinary holograms such as a miniature plant; also, of transparent things like small, clear lightbulbs.

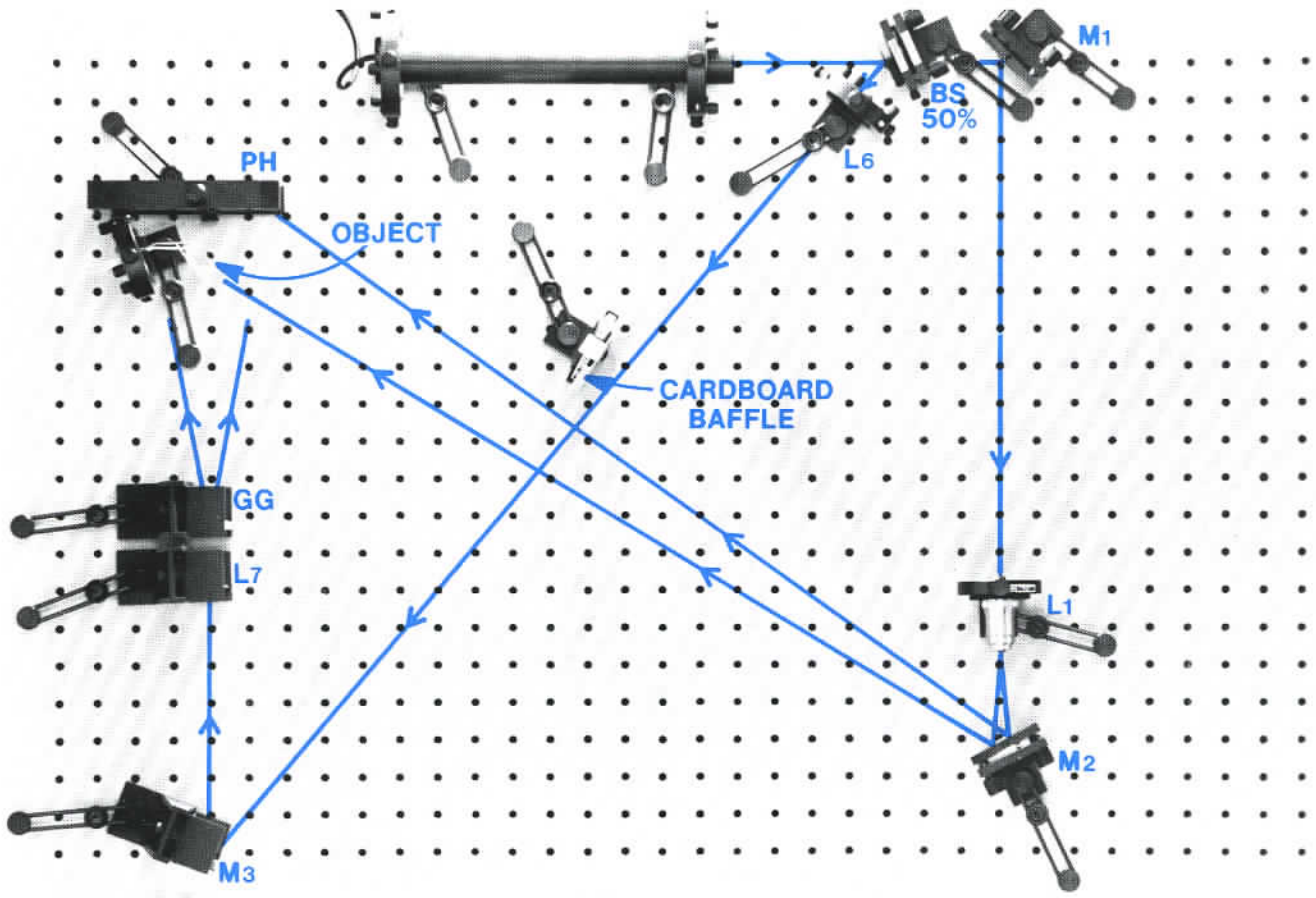

HOLOGRAPHIC STEREOGRAM PORTRAITS (viewable in white light)

You can produce 3-D holograms of people, or of any large-scale objects. Starting off by taking two 35mm slides in the form of a stereo pair, you then permanently capture these images onto a hologram, which conveys a vivid sense of depth when viewed.

Checklist

1. Preferably take your photos on Panatomic-X film, and use reversal processing to get positive slides from the film instead of negatives. (You'll need a direct-positive developing outfit from your photo store, also some fixer, a film-developing tank, and some standard frames for mounting your slides.) Or, use ordinary color slides if you prefer.

2. Ideally, a pair of side-by-side cameras should be used to take the stereo photos. (For stationary scenes you can use a single camera, sliding it left and right between shots.) Refer to the sample slides included in the HL-1a kit.

3. Before setting up this experiment, the elevator bases under the laser and under microscope objective L_1 should be raised up .15" from the bottommost position, that is to the half-way position in height (3.15" optical axis). The experiment will require alternately raising and lowering microscope objective L_1 a bit from the 3.15" axis.

4. The plateholder is mounted 5" vertical x 4" horizontal.

5. Use the 5%-reflecting insert for the beamsplitter. Adjust the reflected beam to hit the center of the plateholder after reflecting from mirror M_2 .

6. Check that both beam paths (from the beamsplitter to the center of the plateholder) are the same length.

7. Mount lens L_4 curved side toward the paper in the plateholder, spaced 6.25" from it. Place L_4 such that the beam hits the same spot (the center) of the paper after L_4 is in place as it did before.

8. Position L_5 such that the light passes through it as well as L_4 , and hits the same spot (the center) of the paper after L_5 is in place as it did before.

9. Position the microscope objective L_2 such that the broad beam transmitted via M_2 will cover the central area of L_5 .

10. The photo slide is in a vertical holder, spaced 9.25" from the plateholder. The side it's viewed from faces toward lens L_5 . The picture stands on its left edge.

11. Groundglass GG spreads the laser light over the area of the plateholder.

12. Mask off the lower half of the groundglass to 3" optical axis for the right-eye holographic exposure, the upper half for left-eye, and adjust L_1 up or down to illuminate the unmasked portion; insert the corresponding slide, left-eye or right-eye (see 10), and position it with respect to parallax. Both exposures are made on a single hologram plate as a double exposure. Return the filmplate to a lighttight box during left-vs-right adjustments.

13. The tall mount near the plateholder serves to keep the direct light through the groundglass from striking the edge of the filmplate. Additionally, for best results you may wish to minimize stray light throughout the set-up by blocking it with cardboard, etc.

Exposure Time (room darkened)

About 10 seconds for each of the two exposures using a 2-milliwatt laser, 8E75HD film; 20-30 seconds with 120-type film. Emulsion side toward laser beam.

Film Processing (room darkened)

Same as page 3.

Viewing the Hologram

Face yourself toward an overhead light bulb or the sun (rather than a broad source). View the hologram with the emulsion side toward you, the light shining down on the hologram from above and behind it. Move the hologram slightly left and right to align it perfectly with the light bulb.

These holograms look especially good when the light source is narrow (left to right) but extended (in height or length). You can get a narrow-source effect with a Tensor-lamp if you stand alongside of it rather than in front of it. That is, beam the lamp directly off toward your left and turned only slightly toward you.

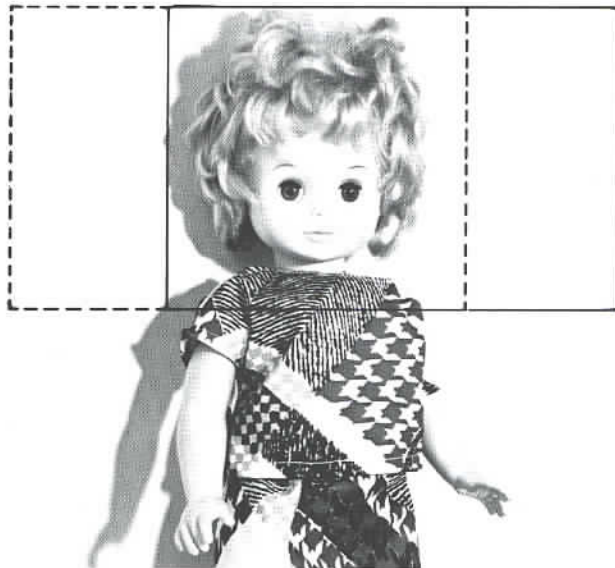
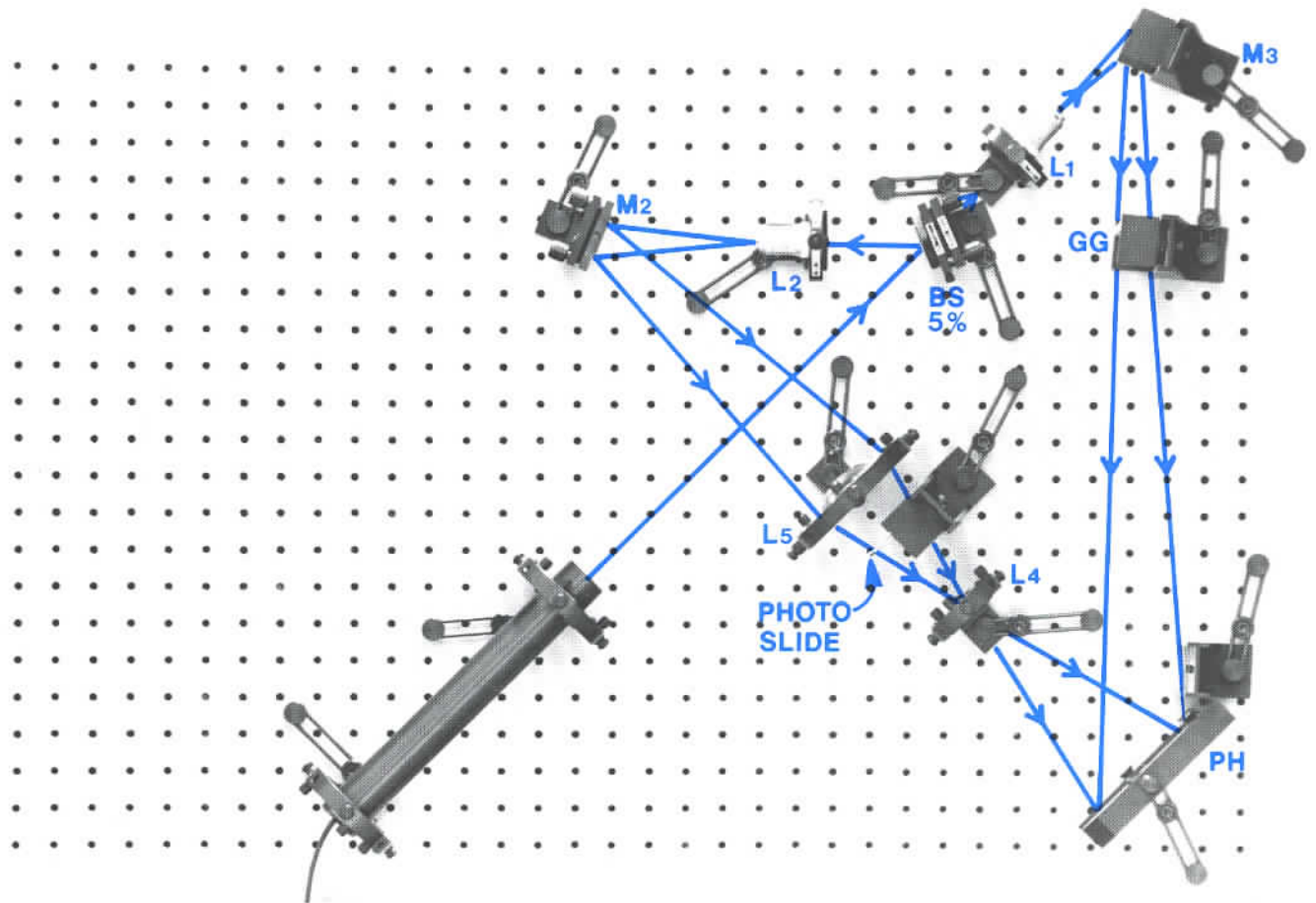

You can create your own stereoscopic pair simply by displacing a single camera (left to right) between shots, without changing the camera angle. A good rule of thumb for the displacement is about 25% of the camera-to-object distance, or you can exaggerate the depth effect by increasing the displacement. By appropriate shifting of the transparencies during mounting, the object should be made to appear near the center of each slide. Such manipulation won't be noticeable provided your photography has been done with a black background.

OPTICAL IMAGE PROCESSING

Coherent laser light can be put to use in a wide variety of ways for manipulating optical images. A big advantage (compared to digital computers) is that optical processors can carry out their jobs so quickly – at the speed of light, in fact.

In the following experiment, the optical processor serves to separate out two distinct images from a pair that had been double-exposed onto a single photo. This is the basic concept of certain special-purpose image storage schemes – to store the images overlapped as multiple exposures, then pull them out individually as they're needed.

Alignment Checklist

1. The light transmitted by the concave lens L_3 becomes a broad beam covering the central portion of lens L_5 .

2. The double-exposure (A and B overlapped) photo slide, held in a tall mount, is imaged by lens L_5 to a location 12" beyond the lens. A piece of white paper, in the plateholder, will make this projected image visible.

3. About 5" beyond L_5 the light focuses to a spot. If you hold a piece of paper there, you'll find that actually there is one point that's quite bright, plus a number of other less bright points. Half of the points will hit along a line that runs up and down from the bright central point, and the rest will hit along a line that runs left and right from the central point.

The vertical string of points comes from the one image in the double exposure, the horizontal string of points from the other. The purpose of step 4 will be to selectively remove the one image simply by blocking off the vertical string of points.

4. Take one of the tall mounts (T_1) and bring it to where its vertical edge will block off the bright central point and the entire vertical string of points, as well as the left or right half of the horizontal string of points, but will let pass the rest of the points in the horizontal string, either those that run left of the central point or those that run right of it.

5. Now study the image that's being projected. It will be relatively dim, but now it will contain only one or the other portion of the double exposure, not both.

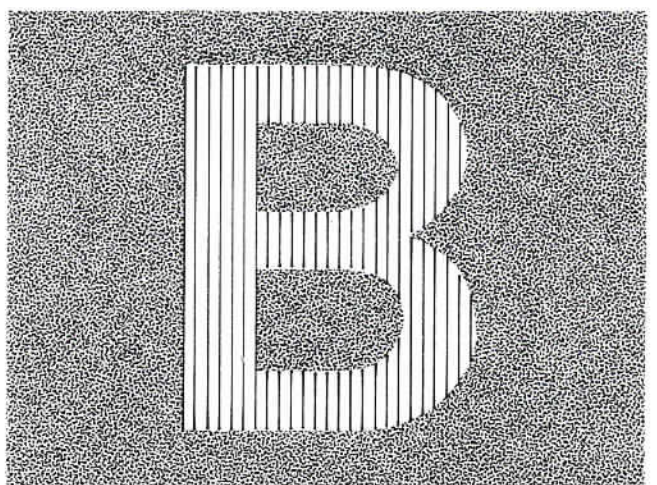
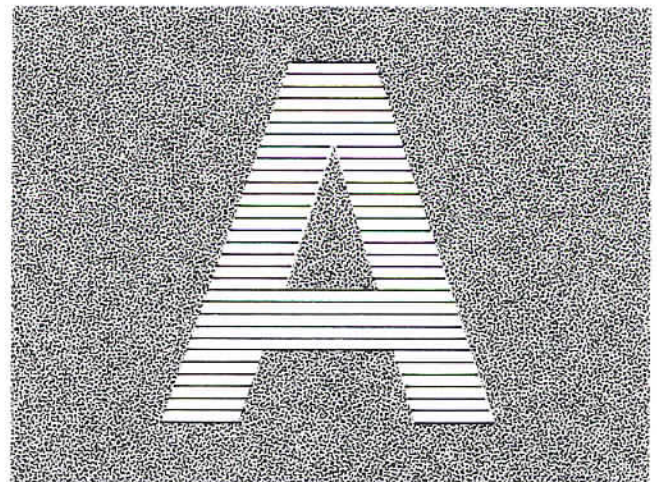
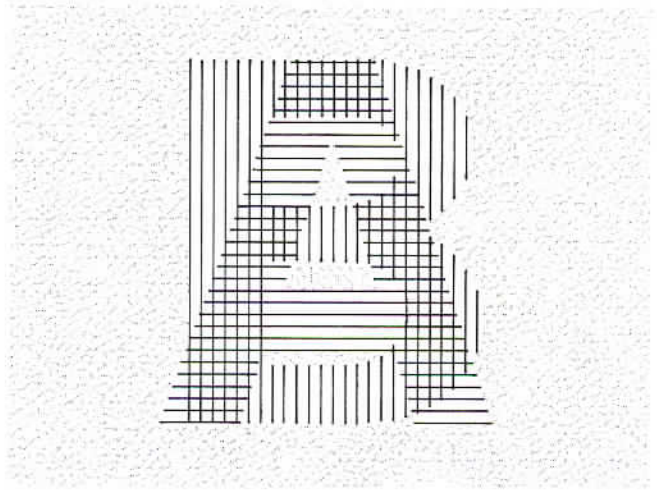

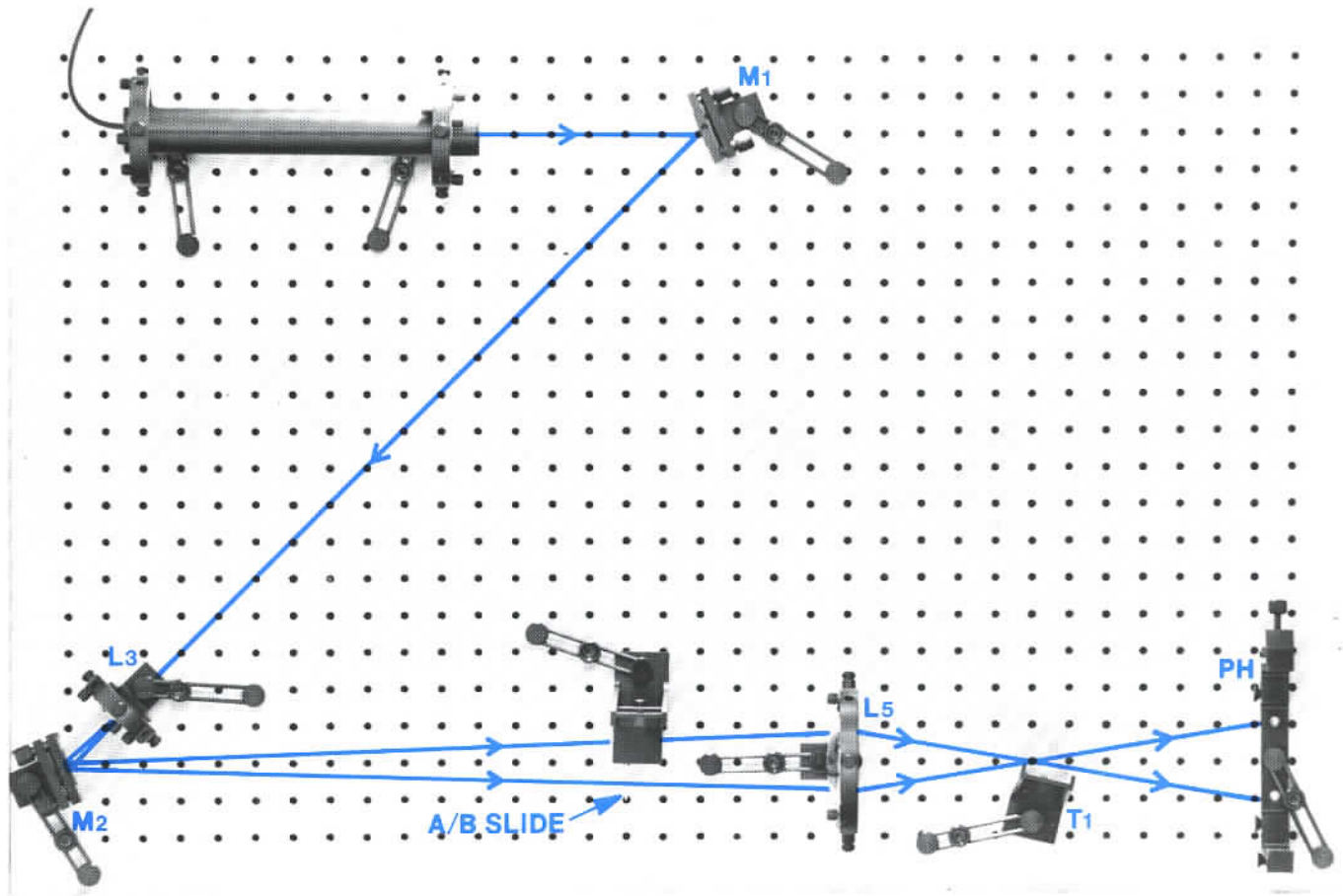

OPTICAL DATA STORAGE

Holography provides a very effective method for taking huge amounts of information and storing it on a microscopic scale. The information can be read out from the hologram merely by shining a laser beam with the proper orientation.

The principles of microscopic storage and readout can most conveniently be studied using familiar data like numbers, boldly contrasting against a uniform background; afterward, you may wish to redo the experiment with a more finely detailed pattern, which you can make up out of numbers, letters, binary bits, or pictorial scenes.

Alignment Checklist

1. Use the 5%-reflecting insert for the beamsplitter.
2. Check that both paths (from the beamsplitter to the center of the plateholder) are the same length.
3. The flat surface of lens L_5 should be spaced about 5" from the plateholder.
4. The light transmitted by microscope objective L_2 spreads as a broad beam to cover the central area of lens L_5 .
5. The 35mm slide of the number pattern, in a vertical holder, is spaced a total of 6" from the plateholder. The pattern stands upright, facing away from lens L_5 .
6. Preferably you should mask off the light from mirror M_1 from hitting the outer edges of the slide mount and the outer portions of lens L_5 . To do this you can tape pieces of cardboard onto the tall mount that holds the slide, or onto the tall mount near lens L_2 .
7. Adjust the position of lens L_5 , back and forth from the plateholder, until the size of the beam striking the filmplate is about $\frac{1}{8}$ " diameter.
8. Lens L_1 spreads a reference beam onto the filmplate. This should be brighter than the object beam, which is the light that comes through lens L_5 and the number-slide.

Exposure Time (room darkened)

About $\frac{1}{4}$ second with 2-milliwatt laser, 8E75HD film; $\frac{1}{2}$ to 1 second with 120-type film. Emulsion side toward laser beam.

(You can put several, or many, text-slides of information onto a filmplate by making a sequence of exposures, translating the filmplate slightly between exposures.)

Devise a cardboard mask with a small aperture for the reference beam, so as to just illuminate the small area that overlaps the object beam. This mask can be taped onto the tall mount near the plateholder.

Film Processing (room darkened)

Same as page 3.

Reading out the Information (room lights dimmed)

Replace the hologram in the plateholder, but flipped around left to right (the emulsion facing away from lens L_5) and the object beam through L_5 blocked off by cardboard.

Remove microscope objective L_1 from its mount. Using mirror M_1 , adjust the laser beam directly onto the main exposed portion of the hologram. A display of the printed material will be projected out from the emulsion side of the plate. It can be viewed by holding a piece of groundglass 6" away from the plate.

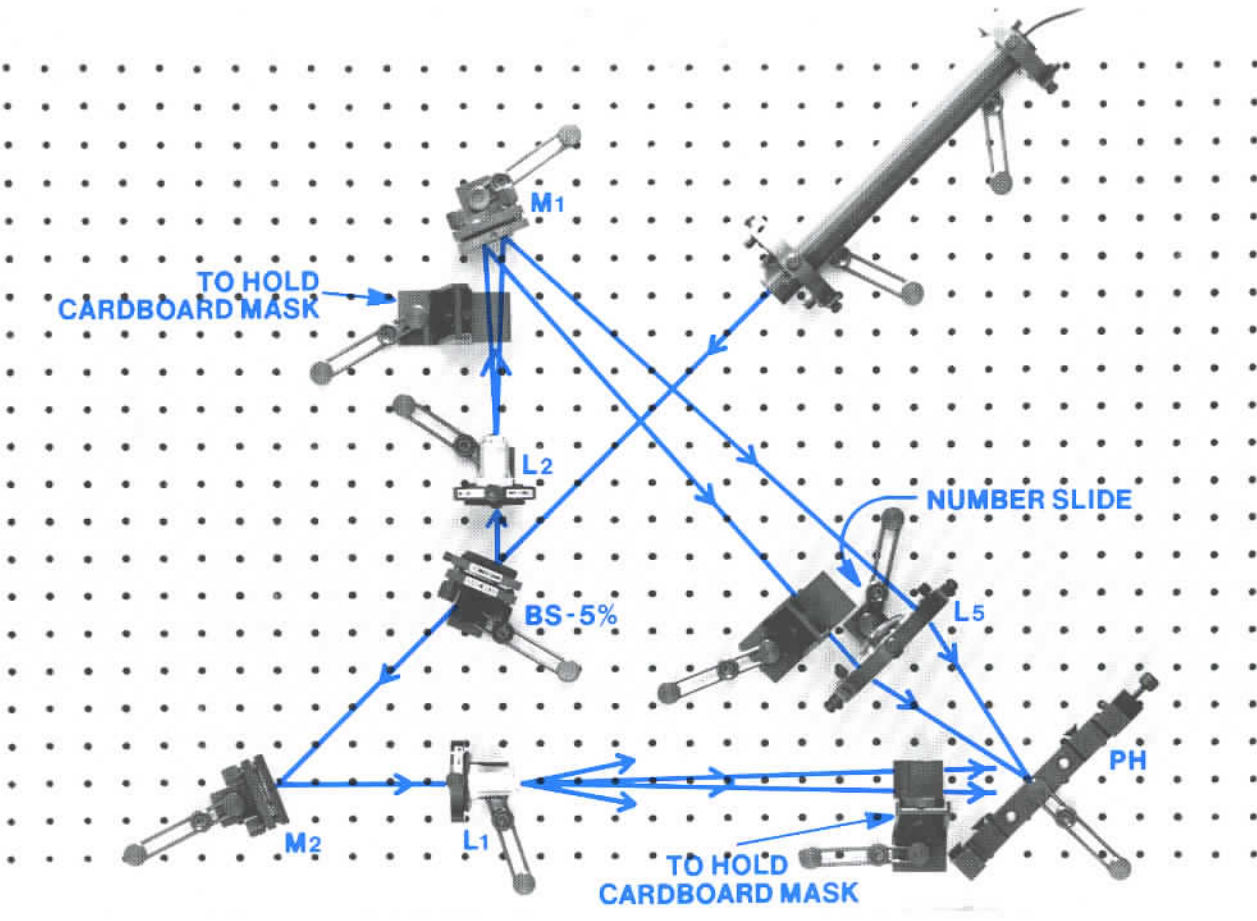

HOLOGRAPHIC INTERFEROMETRY (double exposure)

Holographic interferometry is an amazing visual technique. It allows us to directly observe the slight deformations that an object undergoes whenever small stresses of any kind are applied to it. The technique is extremely sensitive – so sensitive, in fact, that it often reveals peculiarities in the object’s inner structure, such as flaws, etc.

This experiment illustrates the basic principle of holographic interferometry, which is this: to make evident, on an object, any (even slightest) movement of its surface.

An aluminum can will be stressed by a rubber band slipped around it, and we’ll make a type of hologram which shows clearly how the stress has deformed the can.

This is a double-exposure hologram. The can is stressed during one exposure but unstressed during the other – yielding an image that shows “before” vs. “after”.

Alignment Checklist

1. Same setup as for the two-beam transmission hologram on page 4. Use the 5%-reflecting insert for the beamsplitter.
2. Recommend: spray a light coat of flat-white paint onto the aluminum can. It will dry in a few minutes and will eliminate the harsh reflections of the shiny aluminum.
3. Put a few touches of glue on the bottom of the can to attach it to the isolation platform. The side of the can facing the plateholder should sit over the X’s in the photo.
4. Make a double-exposure hologram, giving each of the two exposures about 7-10 seconds with 8E75HD film, 20 seconds with 120-type film. Before turning out the lights to make the double exposure, slip a rubber band around the aluminum can – a weak rubber band, not too tight.

In the dark, in between the first and second exposures, you must not disturb or push on the film plate, or on any other part of the apparatus – just very delicately slip the rubber band off the can. This removing of the stress is what causes infinitesimal movement of the can’s surface. Wait a minute, then make the second exposure.

Film Processing (room darkened)

Same as page 3.

Viewing the Holographic Interferogram

Put the dried plate back in the plateholder, as it was during exposure. Replace the 5% beamsplitter insert with the 100% insert, and fine-adjust it to direct all the energy to the reference beam, illuminating the hologram plate.

On the holographic image of the can you’ll see a pattern of irregularly curved stripes and rings, called interference fringes. These indicate flexing of the can – actually a change (movement) in flexing between the first and second exposures. Notice that the area near the rubber band flexed the most, and the bottom of the can hardly at all.

The amount of movement at any specific point on the plate can be determined by the number of fringes that you count just up to that point – somewhat like tree rings, but counting upward from the base of the can to whatever point you’re trying to measure. In this setup, the fringes you count represent successive increments of 3.7×10^{-4} mm of movement. For example: Starting at the base, if you have to pass over 5 irregularly shaped fringes in order to get to some point of interest, then you know that that point moved 18.5×10^{-4} mm when the stress was relaxed between the two exposures.

The movement you calculate by this count is motion that has occurred perpendicular to the surface of the can. Moving around the can, some areas are bulged out and some are dimpled inward. (See if you can tell which is which.)

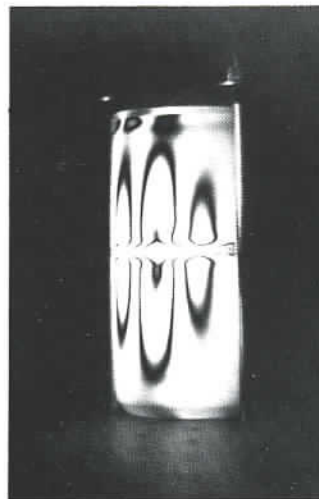

In this experiment, the contour lines show the stress pattern of a rubber band wrapped around an empty aluminum pop-top can.

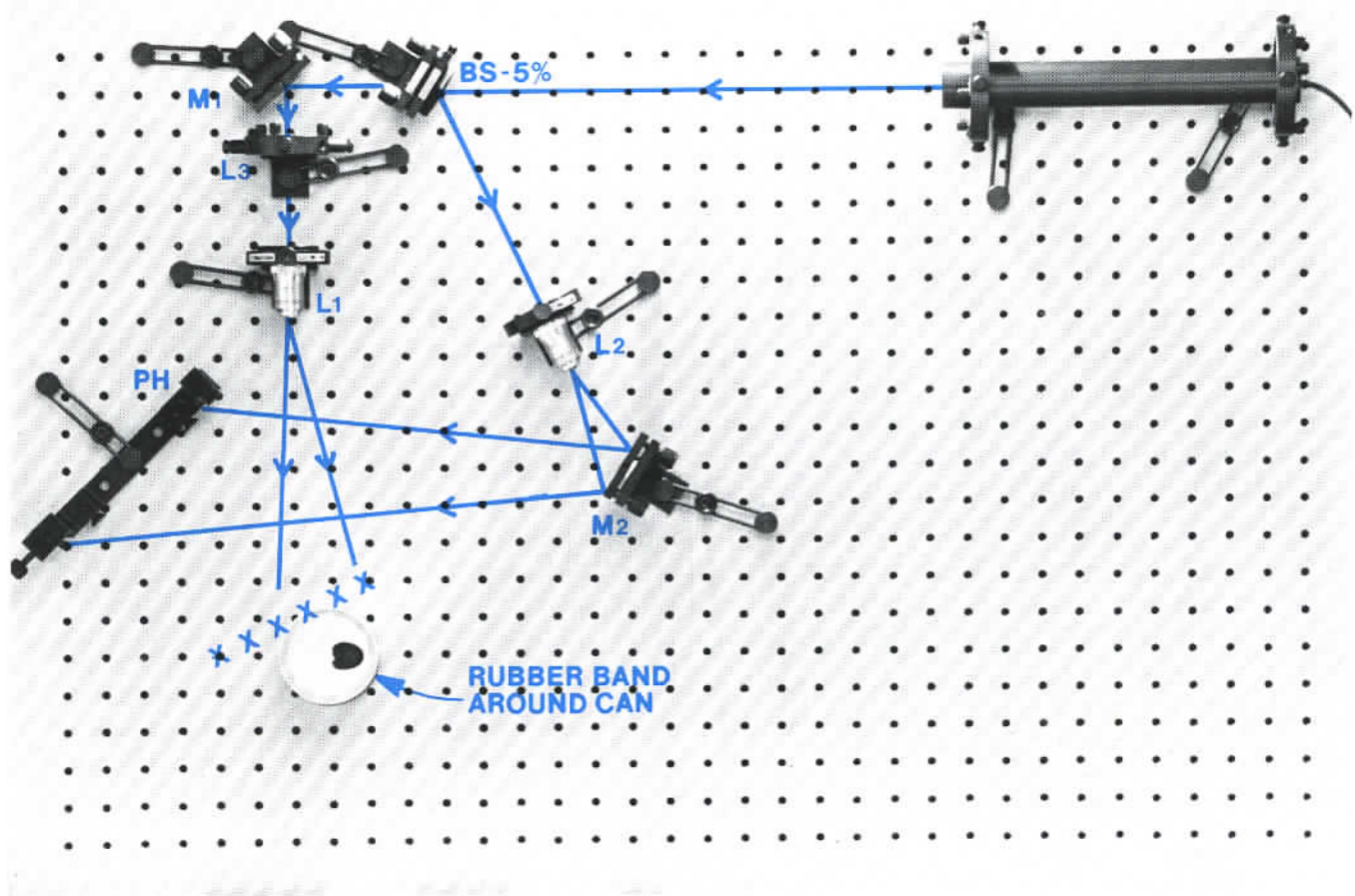

REAL-TIME HOLOGRAPHIC INTERFEROMETRY

Here is a way to watch without interruption every little structural disturbance that may occur in an object – disturbances caused by the slightest stresses, by even the lightest touch of your finger.

Because this is so convenient – watching the effects right as they occur – the real-time method is often used for quality-control testing of manufactured parts.

Note: In industrial situations the technique is made even more convenient when real-time (thermoplastic) film material is used – film which can be developed instantly by an electronic process.

Checklist

1. Same setup as for the two-beam transmission hologram on page 4. Use the 5%-reflecting insert for the beamsplitter.
2. Spray a light coat of flat-white paint on the can to eliminate harsh reflections from the shiny aluminum.
3. Put a few touches of glue on the bottom of the can to attach it to the isolation platform. The side of the can facing the plateholder should sit over the X's in the photo.

Exposure (room darkened)

Single exposure, about 15-20 seconds with 8E75HD; 30-40 seconds with 120-type film.

After the exposure, don't disturb anything in the setup.

Film Processing (room darkened)

Same as page 3.

Viewing the Real-Time Fringes (room lights dimmed)

Put the dried plate back in the plateholder exactly as it was during exposure; don't disturb anything, not even the beamsplitter. Let the laser beam shine into the setup.

Looking through the hologram, you see two things at once – the can itself, plus the holographic image of it, and the two look identical to each other. To compare the two, momentarily hold a piece of cardboard near the beamsplitter and use it to block off first the object beam, then the reference beam.

When you view both simultaneously, though, there is optical interference between them, and fringes appear on the can. Any deformations of the can, which you might cause simply by touching it, are indicated by changes in the fringes.

You may see some fringes even without touching the can. This is simply because the hologram plate has moved slightly, from where it had been during the exposure. Although we may try to get the plate back exactly where it had been during the exposure, usually we only manage to get it approximately there.

Sometimes the real-time fringes can be seen more vividly if we replace the 5% beamsplitter insert with the 50% insert. However, exchanging the inserts will disturb the setup so much that the beamsplitter (and perhaps the object-beam mirror) will require readjustment to achieve proper illumination, and this in itself will cause additional fringes. Still, when you touch the can the fringes will move, which is the important thing.

VIBRATION ANALYSIS (time-average interferometry)

Much of the machinery used in the modern world operates by means of motors and other internal spinning parts. This frequently causes equipment to vibrate and thus make noise.

If it is desired to make some piece of equipment less noisy, the designer needs to first understand precisely the nature of the vibration, and for this purpose time-average holography is quite useful, because it provides a visual display of the vibration.

If a hologram is made of an object that is being steadily vibrated, the resulting hologram will have fringes in the image, which indicate the exact amount of vibration at every point on the object's surface.

Setup

This is the same setup as for double-exposure interferometry on page 18. The only difference is that the object you use in the present experiment is assumed to be one that vibrates.

It is essential that it be an absolutely steady, unchanging kind of vibration. The vibration should be great enough for you to feel it, but rather slight to the touch. For example, you can use a small speaker that's connected to an audio oscillator.

Experimental Procedure

You simply make a single hologram exposure (perhaps 20 to 40 seconds) of your steadily vibrating object. However, the result will be very much like a double exposure.

The vibration is actually a very rapid back-and-forth movement with a brief pause every time before it reverses direction – and it is almost as though you were making a double exposure of these pauses at the two extremes of the motion. In fact it's okay to think of things exactly this way, and so you can measure the amount of motion at any point on the object just as you did in the double-exposure experiment on page 18.

(For more details refer to a textbook, such as *Holographic Interferometry* by C.M. Vest, publisher John Wiley & Sons, N.Y., 1979, especially chapter 4.)

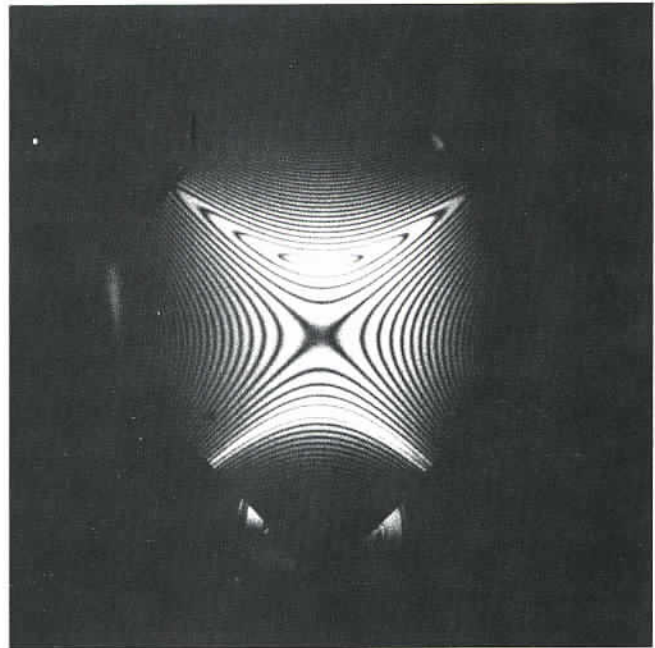

This hologram of a 6" x 6" x 1/8" aluminum plate vibrating at a resonant frequency of about 400Hz was taken with our INSTANT holographic camera. An electronically developed thermoplastic plate is used to produce the hologram right in the camera in less than 10 seconds after exposure. This thermoplastic film is relatively expensive compared to silver halide, but the plate is erasable (reusable more than 300 times) to make per-shot cost low.

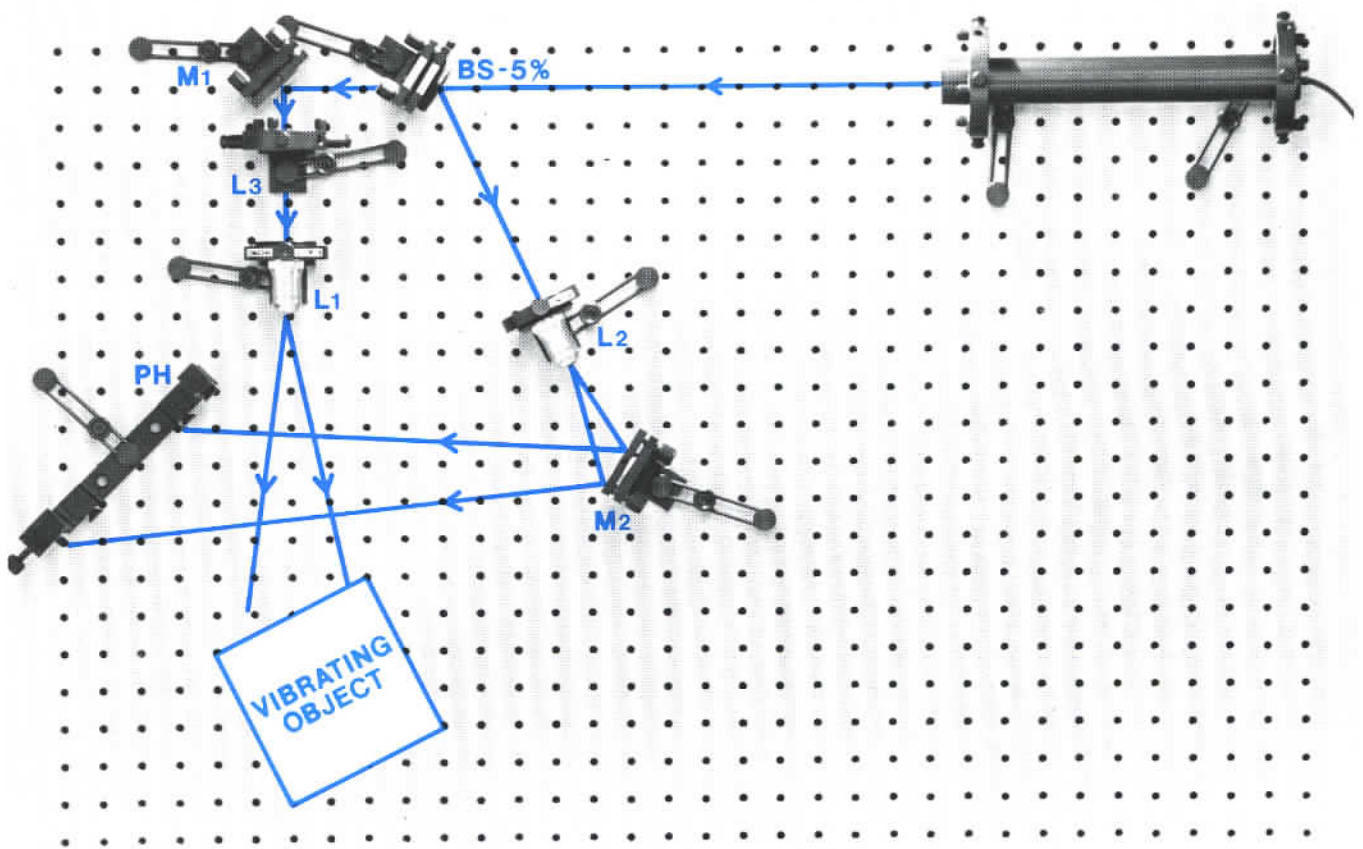

MICHELSON INTERFEROMETER

An interferometer is a kind of setup that's typically used for examining optical components and instruments to see that they don't deviate from proper operating conditions. There are actually many different kinds of interferometers used for many specific kinds of testing.

The Michelson interferometer of the following experiment serves to show up any air drafts (even your breath or the warmth of your hands) which may be flowing over the isolation platform and creating a disturbance.

The way it works is that we precisely match up two separate optical paths against each other, and if the air in the one path ever gets disturbed relative to the other, we'll see undulating fringes (rippling and moving) being projected out of the interferometer.

Something to remember: Provided the fringes you see don't move too much, you can be confident that your air environment provides a good enough place for a holography lab – your optical paths atop the isolation platform won't be prone to disturbances.

Alignment Checklist

1. The portion of the beam that the beamsplitter reflects will strike mirror M_1 . The transmitted portion strikes M_2 .

2. Mirror M_2 reverse-reflects the beam and makes it retrace its way back over exactly the same path, back to the beamsplitter and back to the laser.

3. Fine-adjust mirror M_2 while holding a piece of paper up in front of mirror M_1 . There will be a number of light beams (of various sizes) striking the paper, but by proper adjustment of M_2 you can make several of these beams merge into a single spot of light on the paper. Then readjust M_2 slightly until the second-brightest spot strikes just above the brightest one.

4. Microscope objective L_1 is used to spread out the light beam that exits from the interferometer, with the result of displaying the light broadly onto a piece of paper held in the plateholder. If the light beam is too high or too low where it strikes the microscope objective, then you should fine-adjust the beamsplitter to correct this problem, and while doing so hold a piece of paper in front of mirror M_1 .

5. Now, with a piece of paper held in front of M_2 instead, adjust M_1 to merge the several spots that overlap on this paper, and then readjust M_1 slightly until the second-brightest spot strikes just above the brightest one. This will simultaneously make the brightest beam reflected from M_1 transmit out through the microscope objective L_1 to illuminate the paper in the filmplate holder.

6. Remove the paper from in front of M_2 , and tilt M_1 slightly left or right until vertical fringes appear on the paper in the filmplate holder.

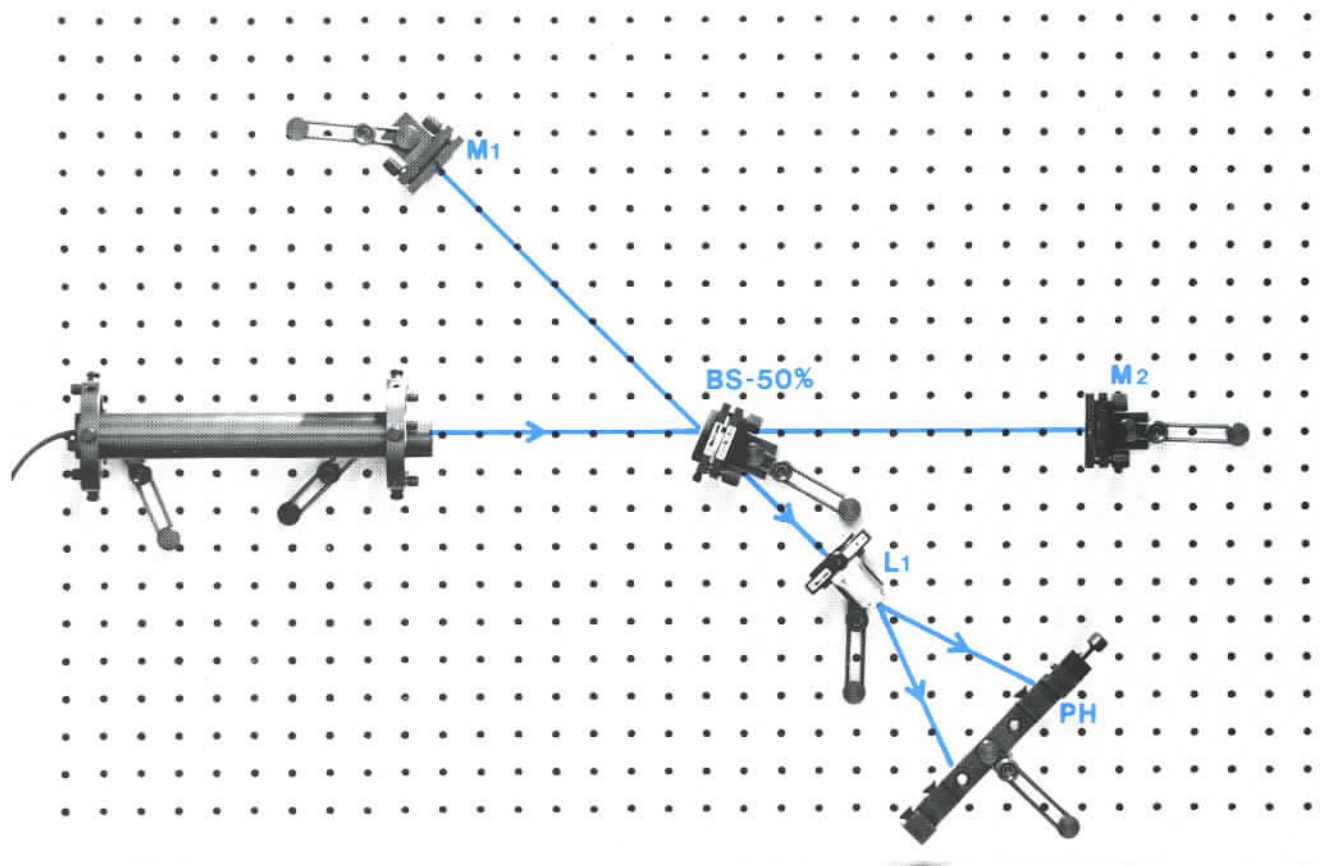

Studying the Interferometer

The following kinds of disturbances which sometimes cause problems in precision laser-optical systems can all be illustrated using the interferometer:

Mechanical Movement. If any components in the setup move unexpectedly (for example from elastic stress-strain or from thermal expansion), even very slight movement, this changes the optical path from one component to another, hence altering the optical effects. You can illustrate this by touching the back of one of the mirror mounts, which will flex it forward slightly, thereby shortening the optical path to the mirror. Notice how this causes fringes to move across the blown-up output display, moving one fringe to the next for each half-wavelength, $.316 \times 10^{-3}\text{mm}$, of motion. (Provided that the base of the mount is fastened down snugly, the mirror will assume its proper condition again as soon as you stop touching it.)

Any motion of the interference fringes would be a serious problem if it were to occur sometime when you're making a hologram exposure, because the motion of the fringes makes a blur on the film.

Thermal Variations. The optical paths can also be affected if there are sudden temperature changes in the air over the top of the isolation platform, especially if this happens along one laser path but not the other. You can observe the effect by blowing your breath into the one path, or holding a burning match (or even your warm hand) just beneath one of the paths.

Fluctuating Laser Modes. This is a quite different kind of disturbance, and although it occurs in most laser setups it is relatively harmless provided that your optical paths (object beam and reference beam paths in holography, for example) are approximately equal in length.

The most common mode fluctuations are those due to thermal expansion of the laser during the first hour or so after it's turned on. Since the laser is extremely sensitive to such changes of its dimensions, its output beam will noticeably change shape as a result. Actually the beam will change over and over again, from one shape to another, as the laser keeps expanding ever so slightly longer and longer during warm-up.

Fortunately the change of beam shape doesn't cause much movement or blurring of the interference fringes, and so it won't much affect our ability to make holograms.

TEST EXPOSURES

When you're doing a particular holography experiment, you can find an optimum exposure just by taking a single film plate and exposing several different patches on it for various lengths of time.

Here's an easy way to get four distinct exposure patches onto a single film plate:

Take a 4" x 5" piece of black paper (such as the paper that film is wrapped in) and cut a 1" square out of it, such that one corner of the 1" square is located at the very center of the 4" x 5" rectangle. This piece of paper then can be laid over the film in the plateholder with four different orientations, in order to expose four different segments – upper left, upper right, lower left, and lower right.

During your test, deliberately deviate from the exposure you guess to be the best value; instead, take exposures of $\frac{1}{2}$, $\frac{2}{3}$, 1.5 and 3 times whatever is your guess. You can tell if your guess is right, because after development two of the patches will be overly dark and two will be overly light.

Another method is to use our Model EM-1 Exposure Mask. With just one exposure, its six calibrated filter wedges will identify the correct exposure.

HOW TO COPY A HOLOGRAM

You can make replicas of almost any transmission-type hologram you may have.

Return the finished hologram to the plateholder for viewing, that is, illuminated by the reference beam alone. In case you don't already know how the plate had been arranged relative to the reference beam for making some hologram you happen to have, then you'll have to find that out – which you do just by rearranging the position and angle of the plateholder until you've made the image in the hologram look as good as seems possible.

To replicate the hologram, simply expose a piece of film to the reference beam alone, almost as though you were making an ordinary hologram exposure, except for this one difference: Keep the original hologram mounted in the plateholder too, overlaid on top of the fresh film while you make the exposure. This of course will reduce the amount of light that reaches the film, so you'll have to adjust your exposure time to compensate.

REFERENCE MATERIAL

1. R.J. Collier, C.B. Burkhardt and L.H. Lin, *Optical Holography*, Academic Press, New York, 1971.
2. H.M. Smith, *Principles of Holography*, (second edition), John Wiley and Sons, New York, 1975.
3. C.M. Vest, *Holographic Interferometry*, John Wiley and Sons, New York, 1979.
4. R.K. Erf (Ed), *Holographic Nondestructive Testing*, Academic Press, New York, 1974.
5. ASM Committee on Holographic Inspection (J. Romano, chairman, et al), *Inspection by Optical Holography*, ASM Metals Handbook, Eighth Edition: Nondestructive and Quality Control, 198-222, (1976).
6. T.H. Jeong, *The Principles of Holography*, The Optical Industry and Systems Purchasing Directory, 26, Book 1, B-337-335 (1980).
7. E.N. Leith, *White-Light Holograms*, *Scientific American*, October 1976, p. 80.
8. Michael Wenyon, *Understanding Holography*, Arco Publishing Co., New York, 1978.
9. C. Outwater and E. Van Hamersveld, *Guide to Practical Holography*, HoloVision Laboratories, Venice, CA., 1974.
10. G. Saxby, *Holograms*, Focal Press, New York, 1980.
11. G. Dowbenko, *Homegrown Holography*, American Photographic Book Publishing Co., Garden City, New York, 1978.
12. F. Unterseher, J. Hansen, and R. Schlesinger. *Holography Handbook*, Ross Books, Berkeley, California, 1982

HOLOGRAPHY, NEWPORT, AND YOU

Instant Camera

Newport has recently introduced an instant camera system that uses an electronically developed thermoplastic plate to produce a hologram 10 seconds after exposure. It is this kind of materials breakthrough that makes a new technology practical for wide industrial application.

CLICK

Laser Hardware

Write us for a 128-page catalog/handbook.



Class

A one-day class is conducted by our senior technical staff here in Southern California on Mondays. It emphasizes the practical aspects of holography, with most of the day devoted to lab work. Enough basic theory and concepts will be presented to enable you to use holography effectively and creatively on your own.



Industrial Systems

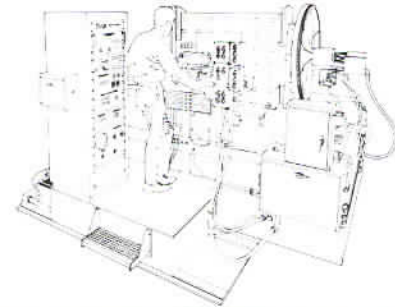

Consulting Services

We can help you determine, quickly, if holography can be applied to your situation. Oftentimes a phone call will be enough to resolve your question. We also accept study contracts to prove feasibility. We charge a nominal daily rate for evaluation testing which usually includes a written report for your reference.



Newport Corporation

The company has its roots at the California Institute of Technology, where our president, vice president and advanced product manager did their doctoral research in the area of holography. Today, Newport is a substantial company that offers almost everything you need for lasers, optics, and holography. We are dedicated to science, and to holography.



Laboratory Systems

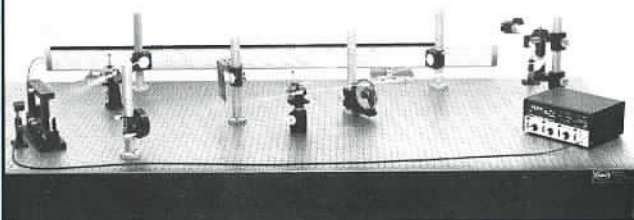

Patents

Certain holographic processes are patented. In light of this, Newport has obtained an exclusive license to produce industrial systems for holographic nondestructive testing, as well as laboratory systems with which one can perform holographic experiments and prove the feasibility of concepts. However, this does not mean that holographic products you may make with these systems can be sold without obtaining the permission of the patent owners. A brief writeup of the holographic patent overview is available upon request.



Holographic Capability = \$2500

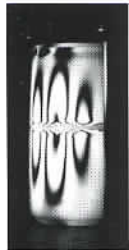
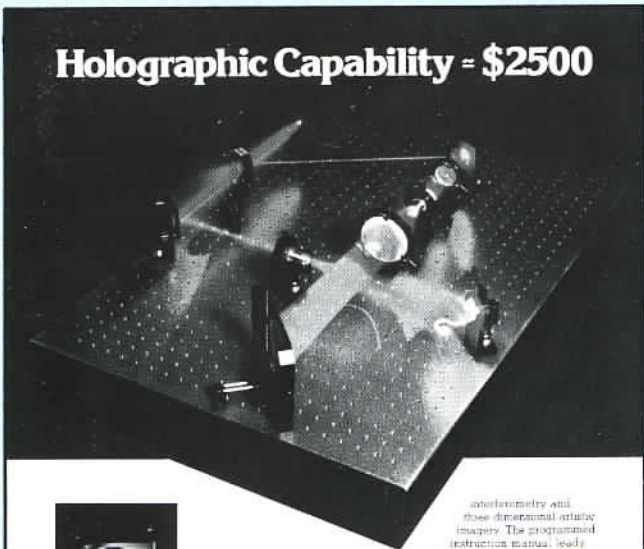

Diode laser excites phosphor screen in He-Ne laser system for a red laser.

The micro-aim sensitivity of holography makes it a unique diagnostic tool. It can find defects when all other techniques fail. Now you can add this capability inexpensively and without the need for prior laser experience. Our versatile system can be used for a broad spectrum of electro-optical experimentation and to explore the exciting areas of optical data processing, mass data storage,

accelerometry and three-dimensional artistic imagery. The programmed instruction manual leads you through thirteen easy-to-follow experiments of fundamental importance.

For a quick start with an advanced overview, take our one-day class here in Southern California. You'll learn how very easy it is to apply holography. The class costs \$250, including text and materials.

THINK LASERS? THINK HOLOGRAPHY! Call today, and we'll send you our new 128 page catalog.

NRC Newport Corporation

18235 Mt. Baldy Circle, Fountain Valley, Calif. 92708 U.S.A.
Phone: (714) 963-9611 Telex: 685535

Press one button...

Just plunk down your favorite objects and see, at a glance, microscopic disturbances. See how your objects deform or distort during small environmental changes or how they respond if you apply slight stresses—mechanical, electrical, thermal, vibration, or whatever.

Our instrument works like a fully automatic photographic camera, but you'll be amazed by what you can see through it. It provides ultra-precise engineering data needed to design parts that can function properly and without failure even under severe conditions.

The basic technique is anisotropy. Everything else is new.

Send us your business card for application notes. Better yet, have a quick try at it here in Southern California.

design data instantly

ALL YOUR LASERS HERE

NRC Newport Corporation
18235 Mt. Baldy Circle, Fountain Valley, CA 92708, Phone: (714) 963-9611 Telex: 685535

Surprisingly, the vibrational contour plots show that several of the "bull's eye" patterns are the point where there is strong vibration in directly opposite directions.

Model 930-647

Newport Optics

We have the **largest** selection of stacked mirrors and beamsplitters... for all wavelengths and with flatness to 1/40 wave. In fact, our all band dielectric mirror works for the entire visible spectrum, independent of wavelength, polarization and incident angles. Imagine that!

The new variable beamsplitter shown here with a krypton 647 nm beam is all dielectric. It is designed to split or attenuate high power laser beams without changing the beam quality or its direction.

We at NRC work hard for you... to make your lab work more enjoyable and productive.

For your copy of our NEW 128-page catalog, write to Newport Corporation, 18235 Mt. Baldy Circle, Fountain Valley, CA 92708. Or phone: (714) 963-9611 Telex: 685535

NRC Newport Corporation

Get protection from all vibration-floor, acoustic, and self-generated

It requires more than just isolating from the floor to get the best out of your instruments. The real trick is to wipe out mechanical resonances, and that's what this table does! Our table systems are internally damped and the curve shows how immune they are to acoustic noise and self-generated vibrations. Our 128 page catalog/handbook contains useful technical discussions and helpful application notes, and is free for the asking.

NRC Newport Corporation
18235 Mt. Baldy Circle, Fountain Valley, CA 92708, Phone: (714) 963-9611 Telex: 685535

Click...Click...Click

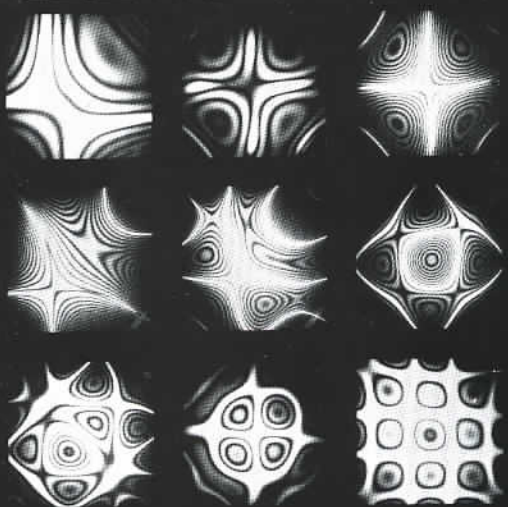

The new holography is that easy

In just seconds a beautiful 3-D image of your test sample is produced with toll-free interfer-ence fringes exposing any internal defects. This powerful QC technique is now that easy.

Explore the ways you can apply holography by attending a **Professional Advancement Course** here in our Southern California facilities. You will make your own holograms in a percentage of class, using both our state-of-the-art real time

camera and our small \$2,000 lab system. Tuition is only \$250, which includes books, supplies and certificate.

Classes are held every Monday. Call us at 714-963-9811 for a reservation.

NRC Newport Corporation

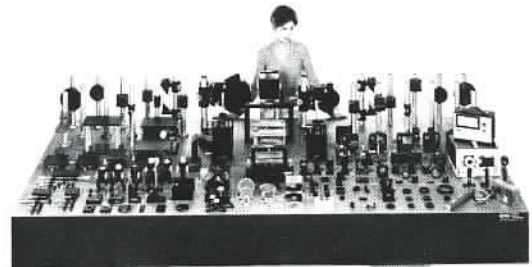

Holographic interferometry in a noisy world with...

The Damped Table

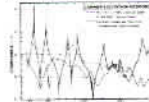

Breakthrough in structural dynamics by our scientists make NRC light-weight honeycomb optical table structures two to three orders of magnitude less susceptible to acoustic excitations when compared to granite, steel girders, and ordinary honeycomb tables. Sub-ported by our patented vibration isolation system, opt. table systems are recognized as being the finest available and can be found in every major laboratory in the United States. The cost, including shipping charges, are not high and can be delivered from stock to anywhere in the world today within a week. Let us show you what a difference a stable foundation makes.

The Damped Rod



A spin-off from our research in damping of large structures is the unique, intensely damped rod. Compared to a conventional solid or hollow rod, the dynamic rigidity is improved by nearly two orders of magnitude. The damped rod, in conjunction with our damped table, will permit the most critical experiments to be performed in extremely noisy environments.

And Some Very Good Components...

that are reasonably priced. Shaped by years of active holographic research, our equipment is characteristically rigid and stable. Stocked in large quantities, we are certain that you will be impressed with both the product quality and service. SEND FOR OUR FREE CATALOG OR REQUEST OUR SALES REPRESENTATIVE TO CONTACT YOU.



NRC Newport Corporation

18235 Mt. Baldy Circle, Fountain Valley, CA 92708 Phone: 714-963-9811 Telex: 685535

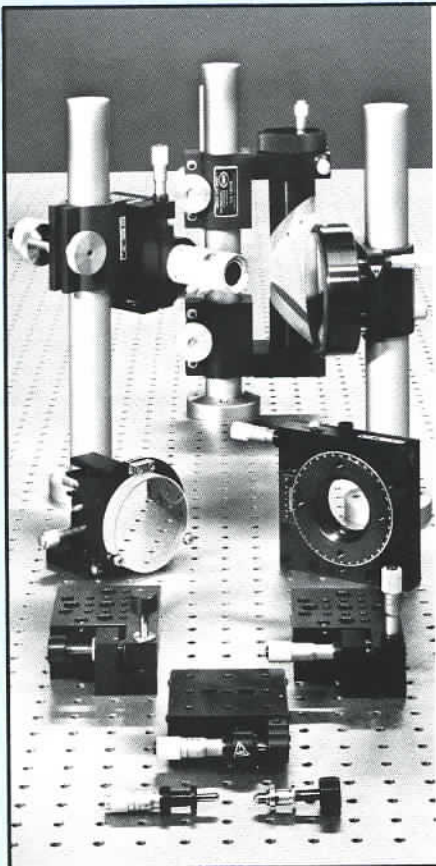

Fine Mechanics

Newport offers a complete range of optical mounts and positioning stages, bearing ultra-fine resolution, precision movement, and intercometric stability. They are reasonably priced and shipped promptly from stock.

An informative 128 page catalog is free for the asking.

NRC Newport Corporation

18235 Mt. Baldy Circle
Fountain Valley, CA 92708
Phone: (714) 963-9811
Telex: 685535



How do you get 1/2" travel and 0.1µ resolution?

Until now, no micrometer could provide both the range and the resolution. Standard micrometers lack the resolution and differential micrometers have 10 times less travel.

New invention

In effect we've built a conventional micrometer into the center of a differential micrometer. A compact, sensitive design.

Feels good, works well

Precision tapped thread makes adjustments extremely smooth. Specifications are lab-tested and verified.

	Course	Fine
Range	13 mm	0.2 mm
Graduation	.01 mm	.0008 mm
Resolution	.001 mm	.0001 mm
Backlash	.001 mm	.0005 mm

Interchangeability

To upgrade your existing instruments, simply substitute this unit for your conventional micrometers. Standard 3/8" mounting shaft.

NRC Newport Corporation

18235 Mt. Baldy Circle, Fountain Valley, Calif. 92708 U.S.A.
Phone: 714-963-9811 Telex: 685535

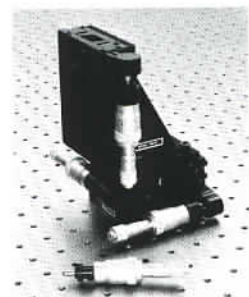

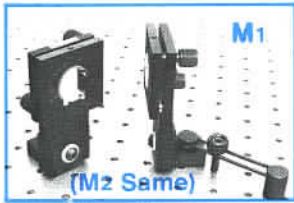

Mount: M1-1.
Mirror: M1-2
Base Clamp: BC-2

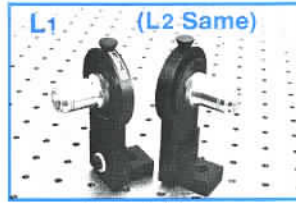

Mount: L1-1
60X Lens: M60X

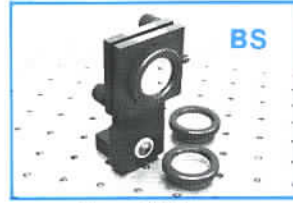

Mount: BS-1
5% Element: BS-2
50% Element: BS-3

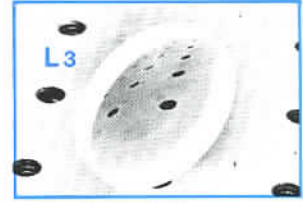

Concave Lens: L3
Chuck Mount (small): AC-1 – not shown

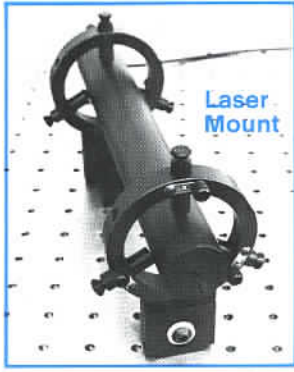

Chuck Mount (medium): AC-2
(two are required to hold laser)

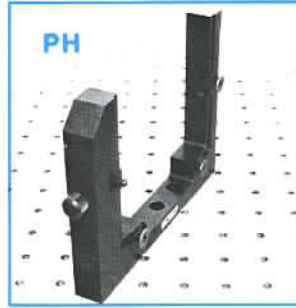

Plateholder: PH

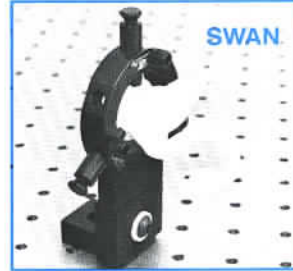

Swan: SWAN
Chuck Mount (small): AC-1

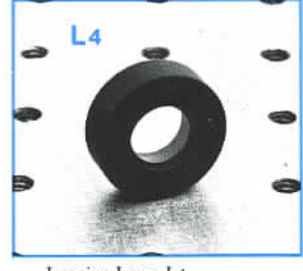

Imaging Lens: L4
Chuck Mount (small): AC-1 – not shown

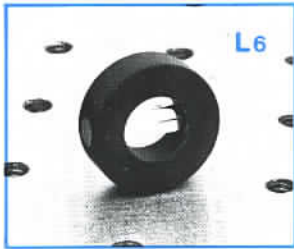

Cylinder Lens (small): L6
Chuck Mount (small): AC-1 – not shown

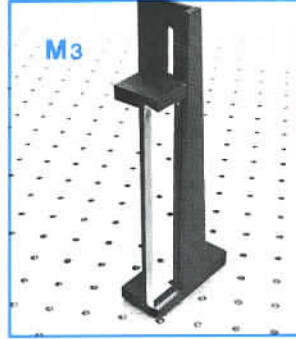

Tall Mirror: M3
Tall Mount: PH-1



Ground Glass: GG
Tall Mount: PH-1

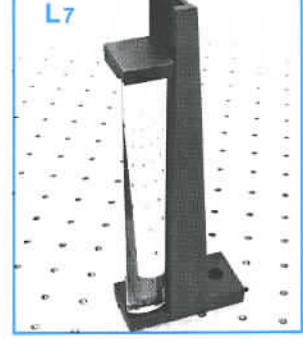

Cylinder Lens (large): L7
Tall Mount: PH-1

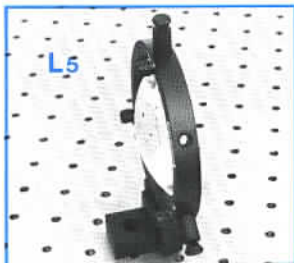

3" Dia. Lens: L5
Chuck Mount (large): AC-3

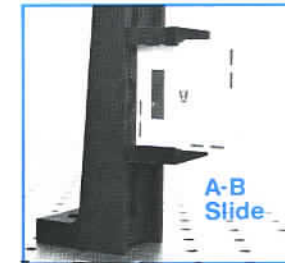

A-B Slide: AB
Tall Mount: PH-1

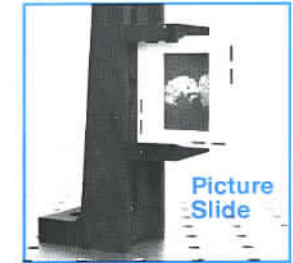

Picture Slide (L & R views):
DOLL-R: DOLL-L
Tall Mount: PH-1

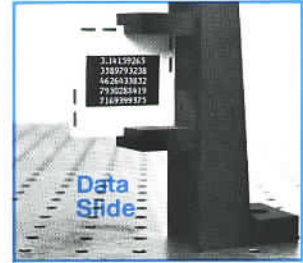

Data Slide: DATA
Tall Mount: PH-1

Packing List

HL-1 (basic experiments): (2) M1-1, (3) M1-2, (2) L1-1, (2) M60X, (2) AC-2, (1) BS-1, (1) BS-2, (1) BS-3, (1) PH, (1) L3, (1) AC-1, (1) SWAN, (9) BC-2, (1) TS-23.

HL-1a (for full capability): (1) GG, (3) PH-1, (1) L4, (1) AC-1, (1) L6, (1) L5, (1) AC-3, (1) L7, (1) M3, (1) AB, (1) DOLL-R, (1) DOLL-L, (1) DATA, (5) BC-2.

TO ORDER PARTS, PLEASE ADD "HL" as a prefix:

Example: 60X lens: HL-M60X

Mount: HL-L1-1

Clamp: HL-BC-2

To order film plates:

4" x 5" 8E75HD-NAH; or Type 120-02 plates







ORDERING INFORMATION

PLACING ORDERS

Orders should be placed directly with the ORDER DESK, either by mail or phone so that they may be processed and entered into the computer without delay.

MINIMUM ORDERS

Due to the high cost of paperwork, please place orders of \$50 or more whenever possible.

WARRANTY

All products are guaranteed to be free from defects in material and workmanship for a period of one year after delivery. Newport does not assume liability for installation, labor, or consequential damages.

RETURN SHIPMENTS

All items returned must have an assigned reference number from the ORDER DESK. Return shipments must be prepaid, and there may be a 25% restocking charge. Film material or optics cannot be returned.

OVERSEAS ORDERS

Newport maintains a limited stock of components and table systems in London, the Hague, Munich, and Paris for off-the-shelf delivery for urgent needs. There is also a product showroom in Paris. Normal delivery of table systems in 6-8 weeks via ocean freight with costs 10-15% of the system's price. Components can be shipped by airfreight or air parcel post with 10-15% of the component's cost being typical. Orders may require a letter of credit drawn on a U.S. bank. All purchases with overseas destinations are subject to a surcharge of 10% to cover special handling and warranty services. Please contact NRC or one of the listed representatives for quotations.

INTERNATIONAL SALES AND SERVICE NETWORK

ARGENTINA

M A B Instrumental S.R.L.
Viamonte 1570 - ler P.
Buenos Aires
Tel: 40-2548 BAIREES
Contact: Jose C. Leone

AUSTRALIA

Quentron Optics Pty. Ltd.
G.P.O. Box 2212, Laser Court
75A Angas St.
Adelaide, South Australia 5000
Tel: (08) 223-6224
Contact: Corbet Stain

BELGIUM

Aims Optronics S.A.
Americaanse Str. 170, Bus 7
B-1050 Brussels
Tel: (02) 647-1978
Contact: Louk de Schutter

CHINA (P.R.C.)

Global Technology Inc.
24248 Crenshaw Blvd., Suite 111
Torrance, CA 90505 U.S.A.
Tel 213-325-7037
Contact: C.P. Wang

Shanghai Office:
P.O. Box 8212
Shanghai, P.R.C.
Tel: 95-1853

TAIWAN (R.O.C.)

Teh Ying Company, Ltd.
3rd Floor, Kingland Bldg.
160, Nanking E. Road, Sec. 2
Taipei
Tel: 561-3485-9
Contact: Jinwell S.S. Kuo

FRANCE

PRODUCT SHOWROOM
Photonetics S.A.
52, Avenue de l'Europe
78160 Marly le Roi
Tel: 3-916-3377
Contact: Dr. Hervé J. Arditty

GERMANY (F.R.G.)/AUSTRIA

Carl Baasel Lasertechnik KG
Sandstr. 21
8000 Muenchen 2
Tel: 089-527051
Contact: Friedrich Meyer

INDIA

Harvin Agencies
6-3-1090/B/4, Raj Bhavan Rd.
Somajigunda, Hyderabad — 500482
Tel: 32508
Contact: Vinod Bhargava

ISRAEL

Isramex Company, Ltd.
25, Arlozorov Street
Tel-Aviv, 62-488
Tel: 248213-4-5
Contact: Nissan Gazenfeld

ITALY

dB Electronic Instruments S.R.L.
Via Teano, 2
20161 Milano
Tel: 6469341-2-3
Contact: Aurelio Pessina

JAPAN

Kyokuto Boeki Kaisha Ltd.
7th Floor, New Otemachi Bldg.
2-1, 2-chome, Otemachi
Chiyoda-ku, Tokyo 100-91
Tel: 244-3511
Contact: K. Anzai

KUWAIT

The Kuwait and Middle East Co.
P.O. Box 757 Safat
Tel: 412832
Contact: P. Varghese

NETHERLANDS

Koning en Hartman Elektrotechniek B.V.
P.O. Box 43220
30 Koperwerf
2504 AE The Hague
Tel: 70-210101
Contact: Hans Siedsma

SPAIN

Lasings, S.A.
Ribatallada, 8 Aptdo. 123
Sant Cugat Del Valles (Barcellona)
Tel: (93) 674 8011
Contact: José M. Iglésias Santana

SWITZERLAND

W. Stolz AG
Taefernstrasse 15
CH-5405 Baden - Daettwil
Tel: 056-840151
Contact: Dr. Beat Ineichen

UNITED KINGDOM

Metax Limited
P.O. Box 315
Gladstone Road
Croydon, Surrey CR9 2BL
Tel: 1-689-6821
Contact: Bob Roberts

 **Newport Corporation**

18235 Mt. Baldy Circle
Fountain Valley, CA 92708
(714) 963-9811; Telex 685535